



# Fire Service Collapse Hazard Floor Furnace Experiments

**Steve Kerber, PE**

Research Engineer, Corporate Research

**Matthew Samuels**

Section Manager, Engineering

**Bob Backstrom**

Research Engineer, Corporate Research

**James Dalton**

Contractor, Corporate Research

January 2012



## DOCUMENT INFORMATION

<b>Release Type</b>	<input type="checkbox"/> Internal <input type="checkbox"/> Customer (Confidential) <input checked="" type="checkbox"/> <input type="checkbox"/> External (Public)	
<b>UL Distribution</b>		
<b>External Distribution</b>	National Institute of Standards and Technology	
<b>Date:</b> January, 2012	<b>Keywords:</b> Structural Collapse, Engineered Lumber, Firefighting, Floor Furnace, Engineered Lumber, Modern, Legacy	
<b>Title:</b> Fire Service Collapse Hazard Floor Furnace Experiments		
<b>Author(s)</b>	<b>Department</b>	<b>Email</b>
Stephen Kerber	Corporate Research	Stephen.kerber@ul.com
Matthew Samuels	Engineering	Matthew.samuels@ul.com
Robert Backstrom	Corporate Research	Robert.G.Backstrom@ul.com
James Dalton	Contractor	James.Dalton@ul.com

### DISCLAIMER

In no event shall UL be responsible to anyone for whatever use or nonuse is made of the information contained in this Report and in no event shall UL, its employees, or its agents incur any obligation or liability for damages including, but not limited to, consequential damage arising out of or in connection with the use or inability to use the information contained in this Report. Information conveyed by this Report applies only to the specimens actually involved in these tests. UL has not established a factory Follow-Up Service Program to determine the conformance of subsequently produced material, nor has any provision been made to apply any registered mark of UL to such material. The issuance of this Report in no way implies Listing, Classification or Recognition by UL and does not authorize the use of UL Listing, Classification or Recognition Marks or other reference to UL on or in connection with the product or system.

## Executive Summary

Seven floor furnace experiments were conducted on representative floor construction to develop comparable fire performance data. All assemblies were intended to represent typical residential construction and included dimensional lumber, engineered wood "I" joists and trusses. The assemblies did not include a ceiling and were considered unprotected floor assemblies representative of a basement with no ceiling membrane. Two of the assemblies were coated with a topical treatment to assess its ability to provide additional structural integrity. These experiments are one task of a larger project that examined residential floor systems in different scales of experiments, examining several variables to provide information to the fire service to add to their knowledge of basement fire dynamics and collapse hazards.

Floor collapse times ranged from 2:20 to 18:05. Three fire service tactical considerations were identified and several code implications were discussed. The results of these experiments were combined with a series of experiments conducted by UL in 2008, which took place on the same floor furnace. It was highlighted that the collapse of all unprotected floor systems, including dimensional lumber, happened well within the potential operational timeframe of the fire service. Two additional considerations examine procedures used to determine the structural integrity of the floor is not necessarily reliable, sounding of the floor and the use of thermal imaging cameras.

Code implications discussed include the inability of spray applied fire retardants or intumescent to provide "equivalent" protection to that of a ½ inch layer of gypsum board. Additionally that dimensional lumber and its structural stability when exposed to fire may have changed over time. Older nominal 2 x 8's did not collapse until after 18 minutes while the newer nominal 2 x 10 collapsed at 7 minutes.

## TABLE OF CONTENTS

<b>EXECUTIVE SUMMARY .....</b>	<b>3</b>
<b>1. INTRODUCTION .....</b>	<b>5</b>
<b>2. BACKGROUND .....</b>	<b>6</b>
<b>3. FIRE SERVICE HAZARD DOCUMENTATION .....</b>	<b>7</b>
3.1. FIREFIGHTER INJURIES AND DEATHS DUE TO STRUCTURAL COLLAPSE .....	7
3.2. RESIDENTIAL COLLAPSE TRENDS DISCUSSION .....	11
<b>4. PREVIOUS FLOOR FURNACE EXPERIMENTS .....</b>	<b>11</b>
4.1. NON- STANDARDIZED ASTM E-119 FURNACE TESTING .....	11
<b>5. EXPERIMENTAL DESCRIPTION .....</b>	<b>23</b>
5.1. EXPERIMENTAL METHOD .....	24
5.2. EXPERIMENTAL ASSEMBLY MATERIALS AND CONSTRUCTION DETAILS .....	25
5.3. STRUCTURAL LOAD .....	28
5.4. INSTRUMENTATION .....	29
<b>6. EXPERIMENTAL RESULTS .....</b>	<b>30</b>
6.1. EXPERIMENT 1 .....	31
6.2. EXPERIMENT 2 .....	37
6.3. EXPERIMENT 3 .....	43
6.4. EXPERIMENT 4 .....	49
6.5. EXPERIMENT 5 .....	55
6.6. EXPERIMENT 6 .....	61
6.7. EXPERIMENT 7 .....	68
<b>7. DISCUSSION .....</b>	<b>75</b>
<b>8. TACTICAL CONSIDERATIONS .....</b>	<b>82</b>
8.1. OPERATIONAL TIMEFRAME .....	82
8.2. SOUNDING THE FLOOR .....	83
8.3. THERMAL IMAGING CAMERAS .....	83
<b>9. CODE IMPLICATIONS .....</b>	<b>84</b>
<b>10. FUTURE RESEARCH .....</b>	<b>86</b>
<b>11. SUMMARY .....</b>	<b>86</b>
<b>12. REFERENCES .....</b>	<b>87</b>
<b>13. ACKNOWLEDGEMENTS .....</b>	<b>88</b>
<b>APPENDIX A .....</b>	<b>89</b>

## 1. Introduction

The drive towards engineered construction systems provides economic and productivity benefits to the construction industry with an assumed status quo in fire safety. However, under fire conditions, these engineered floor systems lead to greater risk of structural failure in a shorter time as a consequence of the reduced cross-sectional dimensions of the engineered products as compared to traditional dimensional lumber floor systems. So, despite the superior structural performance of these new products to traditional lumber construction under 'normal' conditions, the trend reverses in a fire environment.

The increased market demand for environmentally sustainable products is driving engineered lumber products to further reduce material mass that could potentially result in even further concern for fire safety in building construction today. These new engineered floor designs tend to incorporate even further material optimizing engineered floor products than were evaluated in previous research. As an example, the engineered lumber products available to be tested in UL research in 2008 (UL, 2008) have changed. Newer engineered lumber products incorporate a low-density design with significantly less mass per linear foot than the first product. Some of these products include trusses and I-beams with cut-outs for ease of installing duct work and hybrid trusses that incorporate engineered lumber and steel members. With the prevalence of engineered floor systems driven by environmental and economic pressures in the construction industry, it is necessary to ensure that fire safety is not compromised when these products are used in building construction today.

Seven fire experiments were conducted on representative floor construction to develop comparable fire performance data. All assemblies were intended to represent typical residential construction and included dimensional lumber, engineered wood "I" joists and trusses. The assemblies did not include a ceiling and were considered unprotected floor assemblies representative of a basement with no ceiling membrane. Two of the assemblies were coated with a topical treatment to assess its ability to provide additional structural integrity.

The seven fire experiments complied with the requirements of ASTM E119 however the applied structural load was modified for four of the seven assemblies. For Assemblies 4, 6 and 7, a uniform load is applied on the floor to fully stress the supporting structural members. This load is generally higher than the minimum design load of 40 lb/ft<sup>2</sup> specified by the building code for residential construction.

For Assemblies 1, 2, 3 and 5, the load placed on the samples was intended to represent a conservative residential loading condition. A load of 40 lb/ft<sup>2</sup> was placed along two of the four edges of the floor assemblies to represent loads around a perimeter of a room, such as furniture. On each sample, two 300 pound concentrated loads were placed near the center of the sample. A mannequin, intended to simulate fire service personnel, represented each concentrated load.

## 2. Background

These experiments are being conducted as part of a grant funded by the National Institute of Standards and Technology (NIST). The grant is titled “Improving Fire Safety by Enhancing the Fire Performance of Engineered Floor Systems and Providing the Fire Service with Information for Tactical Decision Making.” The objectives of this grant are as follows:

- Improving firefighter safety by further educating them of the hazards associated with engineered flooring systems.
- Understanding the impact of span, fuel load, ventilation and fire location to system failure.
- Examine different fire protection methods and develop data to assess their effectiveness.
- Improve occupant safety by allowing for longer egress times.
- Provide data to substantiate code changes related to fire rated engineered floor systems to result in improved building fire safety.
- Advance the practice of measurement science in keeping with the programs' intention and NIST mission.
- Provide a science basis for code improvements to limit occupant and first responder injury and loss of life as well as the tax loss and other fire related liabilities of local, state and federal governments.

The technical plan for this grant project is shown in Figure 1. The task covered in this report is highlighted in red. For results from other tasks or to see the summary report that integrates the results of all of the tasks visit [www.ul.com/fireservice](http://www.ul.com/fireservice).

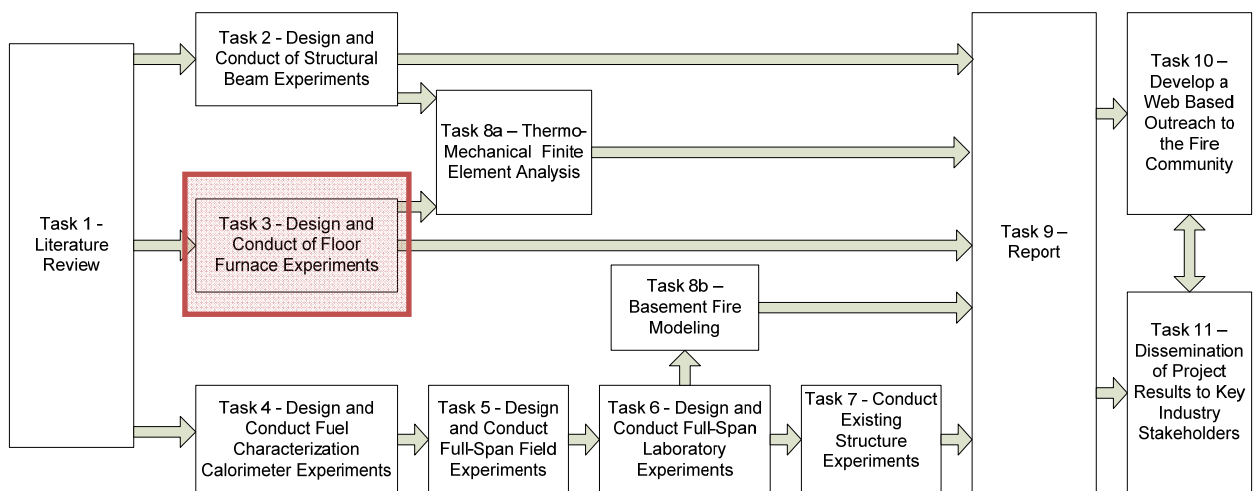

**Figure 1. Project Flow Chart**

### **3. Fire Service Hazard Documentation**

In order to understand the magnitude of the problem for the fire service a review of documented injuries in the International Association of Fire Chiefs (IAFC) firefighter near miss reporting system, a review of the documented LODDs in the NIOSH Firefighter Fatality Investigation Program, a general internet search, a technical publication search and a fire service publication search was conducted.

#### **3.1. Firefighter Injuries and Deaths Due to Structural Collapse**

There has been an overall decline in the numbers of U.S. firefighter deaths since 1977. (Fahy, 2010) This fact is aligned with similar declines in the annual number of structure fires for the same period. However, while there has been an overall decline in both the number of fires and the number of fire fighter fatalities, statistically firefighters are more likely to experience a traumatic injury while operating inside of a structure.

Dr. Rita Fahy cited this counterintuitive trend, “The one area that had shown marked increases over the period is the rate of deaths due to traumatic injury while operating inside a structure. In the late 1970s, traumatic deaths inside structure fires occurred at a rate of 1.8 deaths per 100,000 structures fires and by the late 1990s had risen to approximately 3 deaths per 100,000 structure fires” (Fahy, 2010). The major causes of these traumatic injuries inside structures were determined to be firefighters becoming lost inside, structural collapse, and rapid fire progression (including backdraft, flashover and smoke explosion).

##### **3.1.1. Residential Collapse Trends of NIOSH Firefighter Fatality Investigation Program**

Specific to this research project is the nature of firefighter injuries and deaths due to structural collapse, more specifically the structural collapse of dimensional lumber and/or engineered lumber floor and/or roof assemblies. General trends for incidents investigated by the National Institute of Occupational Safety and Health (NIOSH) Firefighter Fatality Investigation Program were analyzed for the purposes of determining the involved structural systems. The NIOSH Firefighter Fatality Investigation Program provides the most detailed public incident data for fatalities that have occurred since the inception of the program in 1997. Table 1 outlines the incidents, the involved structural system, and the type of assembly (floor or roof) involved in the structural collapse. For additional information regarding specific details for each of the NIOSH investigated incidents visit <http://www.cdc.gov/niosh/fire/>.

**Table 1. Incidents of Structural Collapse Referencing the NIOSH Firefighter Fatality Investigation Program**

<b>NIOSH Firefighter Fatality</b>	<b>Structural Framing System</b>	<b>Type of Assembly</b>	<b>Occupancy</b>
FACE 9704	Dimensional Lumber	1 <sup>st</sup> Floor Assembly	One-story single family residence
FACE 9817	Dimensional Lumber	2 <sup>nd</sup> Floor Assembly	Three-story multi-family residential/commercial
FACE 200232	Dimensional Lumber	1 <sup>st</sup> Floor Assembly	Three-story residential duplex
FACE 200240	Dimensional Lumber	Roof Assembly	2.5 Story single family residence
FACE 200405	Dimensional Lumber	1 <sup>st</sup> Floor Assembly	Two-story townhome
FACE 200509	Dimensional Lumber	Roof Assembly	Vacant one-story residence
FACE 200809	Dimensional Lumber	1 <sup>st</sup> Floor Assembly	Two-story single family residence
FACE 200826	Dimensional Lumber	1 <sup>st</sup> Floor Assembly	Two-story single family residence
FACE 200837	Dimensional Lumber	Roof Assembly	Vacant two-story single family residence
FACE 200923	Dimensional Lumber	1 <sup>st</sup> Floor Assembly	Two-story mixed commercial/residential
FACE 200116	Engineered Lumber / Wood Trusses	1 <sup>st</sup> Floor Assembly	One-story single family residence
FACE 200127	Engineered Lumber / Wood Trusses	Roof Assembly	One-story single family residence
FACE 200206	Engineered Lumber / Wood Trusses	1 <sup>st</sup> Floor Assembly	Two-story single family residence
FACE 200211	Dimensional Lumber	1 <sup>st</sup> Floor Assembly	One-story single family residence
FACE 200624	Engineered Lumber / I-Joist	1 <sup>st</sup> Floor Assembly	One-story single family residence
FACE 200626	Engineered Lumber / I-Joist and Wood Trusses	1 <sup>st</sup> Floor Assembly	Two-story single family residence
FACE 200707	Engineered Lumber / I-Joist	1 <sup>st</sup> Floor Assembly	Two-story single family residence



Generally the majority of the NIOSH Firefighter Fatality Investigations addressing structural collapse determine the fires ability to weaken or compromise areas within the occupancy that are not protected by active or passive fire protection methods. This fact highlights two distinct areas within frame or ordinary constructed buildings where a fire has the ability to burn and weaken exposed structural elements, i.e. the attic area under the roof assembly or the basement area under the first floor assembly. Figure 2 defines the percentage of fire events with respect to floor or roof assemblies.

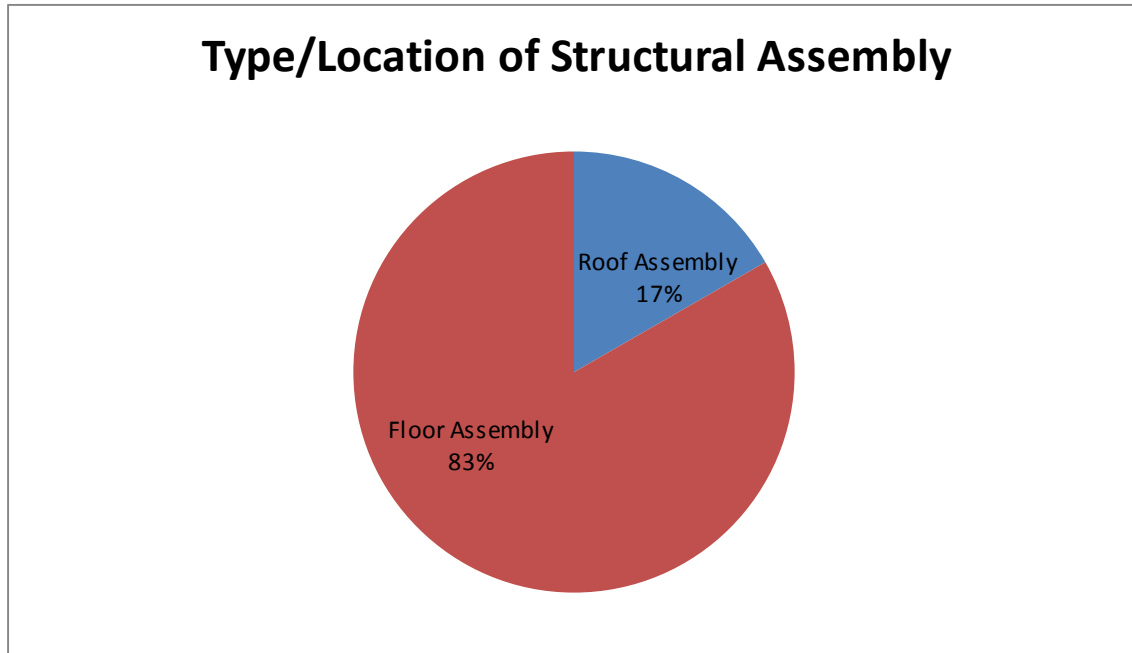

**Figure 2. Structural Assembly Analysis of NIOSH Firefighter Fatality Investigations**

Fires within these distinct areas then burn and weaken the structural elements surrounding the involved fire area. Figure 3 defines the percentage of fire events with respect to framing systems that collapsed during fire ground operations.

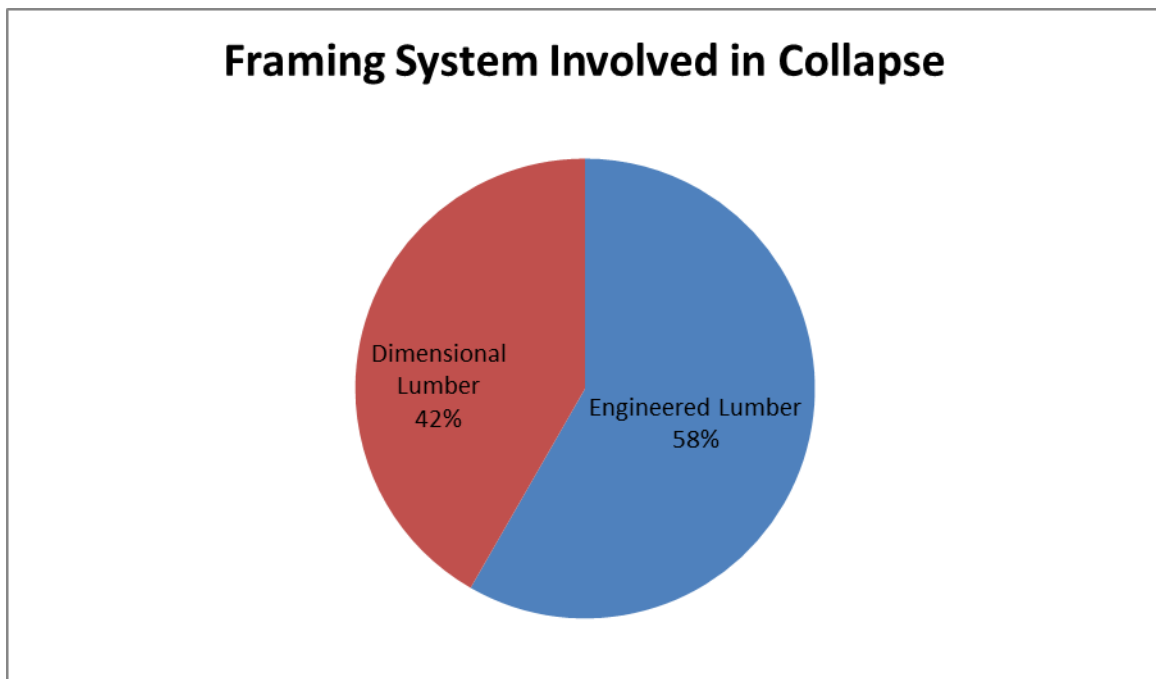

**Figure 3. Framing System Analysis of NIOSH Firefighter Fatality Investigations**

### **3.1.2. Residential Collapse Trends of IAFC Firefighter Near Miss Reporting System**

Fatalities that have been investigated by the NIOSH Fatality Investigation program alone does not provide the entire picture regarding the number of overall annual occurrences of residential structural collapse on the fire ground. Another web-based database created in 2005 by the International Association of Fire Chiefs (IAFC) with the sponsorship of a Department of Homeland Security, Federal Emergency Management Agency (DHS/FEMA) Assistance to Firefighters Grant (AFG) allows for the reporting of firefighter near-miss occurrences ([www.firefighternearmiss.com](http://www.firefighternearmiss.com)). Another website, [www.firefighterclosecalls.com](http://www.firefighterclosecalls.com) has been set up to describe fire service near-miss, injury and fatality incidents. This site identifies the injured firefighters and fire departments.

The National Institute of Standards and Technology (NIST) conducted a review of data from both websites for the period from January 2005 to March 2011. There were 118 incidents reported that involved residential structural collapse. Seventy-six incidents resulted in 128 firefighters being injured. (Madrzykowski, 2011)

### 3.2. Residential Collapse Trends Discussion

There is a distinct trend of structural collapse incidents that have resulted in both firefighter injuries and deaths, specific to residential construction. These incidents highlight performance issues of both unprotected dimensional and unprotected engineered lumber within floor and roof assemblies. As the accuracy of the documentation of the post fire investigations increases, additional photographic forensic evidence has become available to document incident specific failures.

## 4. Previous Floor Furnace Experiments

Several series of experiments have been conducted on the standard floor furnace examining unprotected dimensional lumber and engineered lumber floor systems. There were experiments that followed the ASTM E119 standard and others that followed the standard with the exception of the floor loading conditions. All of these experiments were reviewed and summarized to determine the gaps which needed further experimentation in this research project.

### 4.1. Non- Standardized ASTM E-119 Furnace Testing

There are only a limited number of documented Non-Standardized tests of unprotected combustible assemblies that conform to the ASTM E119, "Standard Methods of Fire Tests for Building Construction and Materials." Non-standardized tests conform to most of the requirements of the ASTM E119 standard, the exception being loading. Numerous agencies have conducted Non-Standardized tests with modified loading conditions, i.e. loading less than 100 % of the design load.

#### 4.1.1. National Engineered Lightweight Construction Fire Research Project Report: Literature Search and Technical Analysis – National Fire Protection Research Foundation, 1992.

**Conducting Agency:** In October of 1992 the National Fire Protection Research Foundation published, "National Engineered Lightweight Construction Fire Research Project Report: Literature Search and Technical Analysis" (Grundahl, 1992). The overall objective of the Fire Protection Research Foundation (FPRF) National Engineered Lightweight Construction Fire Research Project was to define the actual fire performance characteristics of engineered components.

**Report Series:** The components examined in this study include: metal plate connected (MPC) wood trusses, MPC metal-web wood trusses, pin-end connected steel-web wood trusses, wooden I -joists, solid-sawn (e.g., 2 x 10) wood joists, composite wood joists, steel bar joists, and steel C joists. The following is a list of the testing citing for Non-

Standardized ASTM E-119 furnace testing conducted with modified loading conditions respective of the structural elements being examined for this research project.

**Report Results:** The results are summarized in Table 5.

**Table 2. Non- Standardized ASTM E-119 Furnace Testing** (Grundahl, 1992)

Test	Structural Member	Spacing	Structural Failure (min:sec)	Loading (psf) - % Design Stress
NBS 421346 (Son B. , Fire Endurance Tests of Unprotected Wood-Floor Constructitons for Single Family Residences: NBSIR 73-263, 1973)	2 x 10; ½ in. ply. w/blk	16 in. o.c.	11:38	21.0 <sup>1</sup> (40%)
FPL	2 x 10	16 in. o.c.	13:06	40.0 <sup>1</sup>
FPL (R.H. White, 1983)	2 x 10; 23/32" ply.	16 in. o.c.	16:48	11.35 <sup>1</sup>
FPL (R.H. White, 1983)	2 x 10; 23/32" ply.	16 in. o.c.	18:00	11.35 <sup>1</sup>
FPL (R.H. White, 1983)	2 x 10; 23/32" ply.	16 in. o.c.	18:24	11.35 <sup>1</sup>
FPL (R.H. White, 1983)	2 x 10; 23/32" ply.	16 in. o.c.	18:30	11.35 <sup>1</sup>
NBSIR 73-141 (Son B. a., 1973)	6 x 1¾ in. C-joist; ¾" ply. w/carpet	24 in. o.c.	3:45	51.4 <sup>1</sup>
NBSIR 73-164 (Son B. , Fire Endurance Test of a Steel Sandwich Panel Floor Constructiton, NBSIR 73-164, 1973)	6 x 3 in. 14 ga C-joist; top and bottom 3/8" ply.	48 in. o.c.	9:00	40.0 <sup>1</sup>
BMS 92 (Subcommittee on Fire Resistance Classifications of the Central Housing Committee on Research, 1942)	2 x 10; ¾" ply.	16 in. o.c.	N/A <sup>2</sup>	N/A <sup>3</sup>

<sup>1</sup> Assumed to be a limited load test. Loading not 100% of design load.

<sup>2</sup> Ultimate fire resistance time period for exposed wood joists was 15 min.

<sup>3</sup> Loading developing 1000psi maximum fiber bending stress.

**Review and Comment:** The FPRF report and the source literature were reviewed for testing conducted prior to 1992. Non-standardized ASTM E-119 furnace testing provides a comparative analysis to standardized ASTM E-119 furnace testing with one exception, a reduced applied loading. This modified loading conduction results in a reduction in the member design stress. The majority of the tests conducted were of

unprotected dimensional lumber floor assemblies. A summary of these tests results is shown in **Error! Reference source not found.**

#### **4.1.2. Underwriters Laboratories Inc. “Structural Stability of Engineered Lumber in Fire Conditions”, Project Number 07CA42520, File Number NC9140, September 2008**

**Conducting Agency:** The project, conducted by Underwriters Laboratories Inc. in September of 2008, provides fire resistive performance of nine assemblies tested as part of a fire research and education grant sponsored by the Fire Prevention and Safety Grants under the direction of the Department of Home Security/Federal Emergency Management Agency/Assistance to Firefighters Grants.

**Test Series:** Nine fire tests were conducted. Seven of the samples represented floor–ceiling constructions and two samples represented roof-ceiling constructions. A goal of the project was to develop comparable fire performance data among assemblies. All assemblies were intended to represent typical residential construction. Some assemblies included construction features such as 2 by 10 floor joists and 2 by 6 roof rafters that the fire service expressed satisfactory knowledge of their structural performance based upon their experience. Other assemblies included lighter weight wood structural members such as "I" joists and trusses. Two of the assemblies did not include a ceiling (unprotected wood), six of the assemblies included a ceiling, protecting the wood flooring assembly, consisting of 1/2-inch thick regular gypsum board and one assembly included a 3/4-inch thick plaster ceiling.

The nine fire tests complied with the requirements of ASTM E119 but the applied structural load was non-traditional. Typically, a uniform load is applied on the floor or roof to fully stress the supporting structural members. This load is generally higher than the minimum design load of 40 psf specified by the building code for residential construction. For the tests conducted in this study the loading was modified to represent typical conditions during a residential fire. A load of 40 psf was placed along two of the four edges of the floor – ceiling assemblies to represent loads around a perimeter of a room. On each sample, two 300 pound concentrated loads were placed near the center of the sample. A mannequin, intended to simulate fire service personnel, represented each concentrated load. For the two samples that represented roof-ceiling assemblies, the two mannequins were the only live load applied on the test sample.

The construction details of the nine samples are summarized in **Table 3**.

**Table 3. Summary of Test Samples (Underwriters Laboratories, Inc., 2008)**

Test Assembly No.	Supports	Ceiling	Floor or Roof
1	2 by 10s @ 16 inch centers	None	1 by 6 subfloor & 1 by 4 finish floor
2	12 inch deep "I" joist @ 24 inch centers	None	23/32 inch OSB subfloor, carpet padding & carpet
3	2 by 10s @ 16 inch centers	1/2 inch regular gypsum wallboard	1 by 6 subfloor & 1 by 4 finish floor
4	12 inch deep "I" joist @ 24 inch centers	1/2 inch regular gypsum wallboard	23/32 inch OSB subfloor, carpet padding & carpet
5	Parallel chord truss with steel gusset plate connections, 14 inch deep @ 24 inch centers	1/2 inch regular gypsum wallboard	23/32 inch OSB subfloor, carpet padding & carpet
6	Parallel chord truss with glued connections, 14 inch deep @ 24 inch centers	1/2 inch regular gypsum wallboard	23/32 inch OSB subfloor, carpet padding & carpet
7	2 by 6s @ 16 inch centers with 2/12 pitch	1/2 inch regular gypsum wallboard	1 by 6 roof deck covered with asphalt shingles
8	2 by 10s @ 16 inch centers	3/4 inch plaster	1 by 6 subfloor & 1 by 4 finish floor
9	Roof truss with steel gusset plate connections @ 24 inch centers with 2/12 pitch	1/2 inch regular gypsum wallboard	7/16 inch OSB covered with asphalt shingles

**Test Results:** The results of the ASTM E119 fire tests are expressed in terms of hours such as 1/2 hour, 1 hour or 2 hour rated assemblies. These time ratings are not intended to convey the actual time a specific structure will withstand a fire. All fires are different. Variations result from room size, combustible content and ventilation conditions. The ASTM E119 test method does provide a benchmark that enables a comparison of fire performance between test samples.

For unrestrained floor-ceiling assemblies and unrestrained roof-ceiling assemblies such as the tested samples, ASTM E119 includes the following Conditions of Acceptance:

1. The sample shall support the applied load without developing conditions that would result in flaming of cotton waste placed on the floor or roof surface.
2. Any temperature measured on the surface of the floor or roof shall not increase more than 325 °F. The average temperature measured on the surface of the floor or roof shall not increase more than 250 °F.

The results of the nine fire tests in terms of the ASTM E119 Conditions of Acceptance are summarized in Table 4.

**Table 4. Summary of Test Results ASTM E119 (Underwriters Laboratories, Inc., 2008)**

<b>Test Assembly No.</b>	<b>Time of 250°F avg. temperature rise on surface of floor / roof (min:sec)</b>	<b>Time of 325°F max. temperature rise on surface of floor / roof (min:sec)</b>	<b>Flame passage through floor / roof (min:sec)</b>	<b>Collapse (min:sec)</b>	<b>Fire resistance rating (min)</b>
1	*	*	18:30	18:45	19
2	*	*	06:00	06:03	6
3	*	*	44:15	44:45	44
4	*	*	*	26:45	27
5	*	29:15	28:40	29:15	29
6	*	24:15	26:00	26:45	24
7	39:45	38:30	26:00	40:00	26
8	*	*	*	79:45	51**
9	*	*	*	23:15	23

\* - This condition was not achieved during the fire test.

\*\* - Plaster ceiling in contact with furnace thermocouples at 51 minutes. The test method requires that the junction of the thermocouples in the furnace be placed 12 inches away from the ceiling surface at the beginning of the test and shall not touch the sample as a result of deflection.

In addition to the fire resistance rating determined by the Conditions of Acceptance in ASTM E119, a finish rating is typically published for fire resistive assemblies with combustible supports such as the tested as samples. The finished rating is defined as the time when the first occurrence of either: (1) a temperature measured on the face of the combustible supports nearest to the fire increases more than 325 °F or (2) the average temperature measured on the face of the combustible supports nearest the fire increases more than 250 °F.

Several fire test standards similar to ASTM E119 such as ISO 834:1 Fire-resistance tests – Elements of building construction – Part 1: General requirements define load bearing capacity as the elapsed time that a test sample is able to maintain its ability to support the

applied load during the fire test. The ability to support the applied load is detailed in the report (Table 5).

**Table 5. Summary of Significant Events in Addition to ASTM E119 Conditions of Acceptance (Underwriters Laboratories, Inc., 2008)**

<b>Test Assembly No.</b>	<b>Initial falling of ceiling material (More than 1 ft<sup>2</sup>) (min:sec)</b>	<b>Average temperature on unexposed surface of ceiling at initial falling (°F)</b>	<b>Finish rating (min:sec)</b>	<b>Loadbearing capacity (min)</b>
1	No ceiling	No ceiling	00:45	18
2	No ceiling	No ceiling	00:30	4
3	23:30	605	15:30	45
4	17:15	531	7:45	25
5	16:30	519	10:45	24
6	16:00	559	12:15	25
7	15:45	253	15:15	40
8	74:00**	1109	74:00**	80
9	13:45	730	14:45	24

Notes:\*\* - plaster ceiling in contact with furnace thermocouples at 51 minutes

### **Review and Comment:**

- The overall objective of the Structural Stability of Engineered Lumber in Fire Conditions project was to develop comparable fire performance data for unfinished and finished assemblies constructed with dimensional and engineered lumber components.
- Nine fire tests were conducted. Seven of the samples represented floor–ceiling constructions and two samples represented roof–ceiling constructions. All assemblies were intended to represent typical residential construction. Some assemblies included construction features such as 2 by 10 floor joists and 2 by 6 roof. Other assemblies included lighter weight wood structural members such as "I" joists and trusses. Two of the assemblies did not include a ceiling, six of the assemblies included a ceiling consisting of 1/2-inch thick regular gypsum board and one assembly included a 3/4-inch thick plaster ceiling.
- The fire containment performance of a combustible floor-ceiling assembly representing typical legacy construction without a ceiling was 18 minutes. The time duration was based upon the performance of the assembly when exposed to the time-temperature curve defined in Standard ASTM E119. This performance was defined as the bench mark performance for comparison purposes.



- The fire containment performance of a combustible floor-ceiling assembly supported by engineered I joists was 14 minutes less than the bench mark performance.
- The fire containment performance of the combustible floor-ceiling assembly supported by engineered I joists with a ½ inch thick regular gypsum board ceiling exceeded the bench mark performance by 7 minutes.
- The fire containment performance of a combustible floor-ceiling assembly supported by either: (1) engineered I joists, (2) parallel chord trusses with steel gusset plate connections or (3) parallel chord trusses with glued connections were approximately equal when a ceiling consisting of ½ inch thick regular gypsum wallboard was provided.
- Unprotected wood assemblies, both dimensional and engineered components, upon combustion contributed significant fuel loads to the experimental fires raising corresponding temperatures above the standardized ASTM E119 time temperature curve.

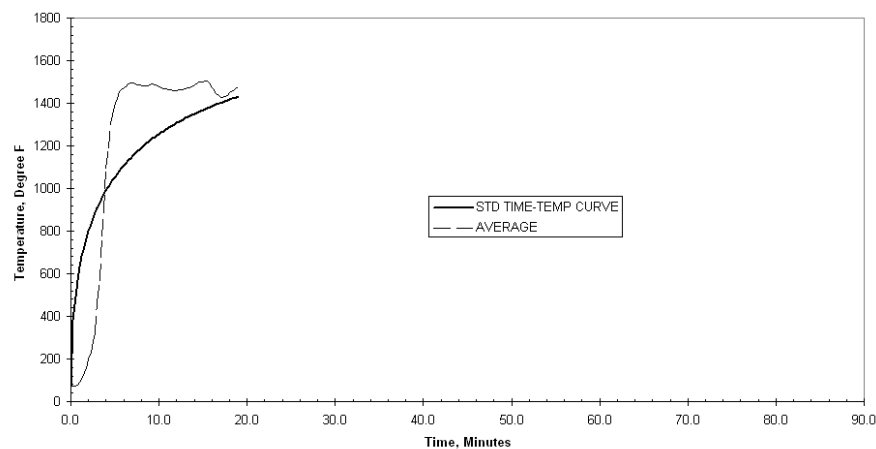

**Figure 4 - UL263 Standard Time Temperature Curve and Average Furnace Temperature vs. Time for Assembly No. 1**

- Unprotected Lightweight assemblies with minimal mass to stiffness ratios exhibited dynamic vibrations prior to structural collapse indicating that the assemblies were significantly weakened far before the end of the collapse time, or end of test.
- Unprotected Lightweight assemblies exhibit a reduced load bearing capacity when significantly weakened by fire as evident in a comparative analysis comparing test standards similar to ASTM E119 with standards such as the ISO 834:1 Fire-resistance tests – Elements of building construction.

#### **4.1.3. Underwriters Laboratories Inc. “Structural Stability of Engineered Lumber in Fire Conditions”, Project Number 08CA33476, File Number NC10412, Submitted to Chicago Fire Department - September 2009**

**Conducting Agency:** The project, conducted by Underwriters Laboratories Inc. in September of 2009, provides fire resistive performance of three alternate assemblies tested in addition to the fire research and education grant sponsored by the Fire Prevention and Safety Grants under the direction of the Department of Home Security/Federal Emergency Management Agency/Assistance to Firefighters Grants. A total of three fire tests were conducted on test assemblies representing floor–ceiling constructions so as to develop comparable fire performance data among assemblies. All the test assemblies were intended to represent typical residential construction.

**Test Series:** The first assembly was constructed with parallel chord trusses with metal gusset connections as the structural components with a regular 1/2” gypsum board ceiling and included the following unique features: Recessed lighting fixture penetrations in the ceiling, HVAC supply and return penetrations in the ceiling, HVAC duct work in the interstitial space above the ceiling, Metal gusset connection on the bottom cord and AFG grant sponsored test # 5 was similarly constructed without the unique features noted above.

The second assembly was constructed with parallel chord truss with glued connections as the structural components. This assembly was similar to the AFG grant sponsored test # 6 with the exception that this test did not include a ceiling.

The third assembly was constructed with parallel chord truss with metal gusset connections as the structural components and included simulated stairwell framing.

The construction details of the three test assemblies are summarized in **Table 6** and detailed in Test Records 1 through 3.

**Table 6. Summary of Test Samples (Underwriters Laboratories, Inc., 2009)**

Test Assembly No.	Supports	Ceiling	Floor or Roof
1	Parallel chord truss with steel gusset plate connections, 14 inch deep @ 24 inch centers with bottom chord splices, can lights and duct work	1/2 inch regular gypsum wallboard	23/32 inch OSB subfloor, carpet padding & carpet
2	Parallel chord truss with glued connections, 14 inch deep @ 24 inch centers	None	23/32 inch OSB subfloor, carpet padding & carpet
3	Parallel chord truss with steel gusset plate connections, 14 inch deep @ 24 inch centers with simulated	None	23/32 inch OSB subfloor, carpet padding & carpet

Test Assembly No.	Supports	Ceiling	Floor or Roof
	staircase and bottom chord splices		

The three fire tests complied with the requirements of ASTM E119 but the applied structural load was non-traditional. Typically, a uniform load is applied on the floor to fully stress the supporting structural members. This load is generally higher than the minimum design load of 40 psf specified by the building code for residential construction. For the tests described in this report, the load placed on the samples was intended to represent typical conditions during a fire. A load of 40 psf was placed along two of the four edges of the floor – ceiling assemblies to represent loads around a perimeter of a room. On each sample, two 300 pound concentrated loads were placed near the center of the sample. A mannequin, intended to simulate fire service personnel, represented each concentrated load.

Standard ASTM E119, Fire Tests of Building and Construction Materials, describes a fire test method that establishes benchmark fire resistance performance between different types of building assemblies. For floor-ceiling assemblies, the standard requires a minimum 180 square foot sample prohibit the passage of flame through the sample and limit the temperature rise at specific locations as the sample while the sample supports a load and is exposed to a standardized fire. The standardized fire represents a fully developed fire within a residential or commercial structure with temperatures reaching 1000 °F at 5 minutes and 1700 °F at 60 minutes.

**Test Results:** The results of the ASTM E119 fire tests are expressed in terms of hours such as 1/2 hour, 1 hour or 2 hour rated assemblies. These time ratings are not intended to convey the actual time a specific structure will withstand an actual fire event due to differences in building configuration and construction, fuel load, and ventilation. However, the results from ASTM E119 test method enable a useful benchmark to compare the fire resistance performance of test assemblies.

For unrestrained floor-ceiling assemblies such as the tested assemblies, ASTM E119 includes the following Conditions of Acceptance:

1. The sample shall support the applied load without developing conditions that would result in flaming of cotton waste place on the floor surface.
2. Any temperature measured on the surface of the floor shall not increase more than 325 °F and the average temperature measured on the surface of the floor shall not increase more than 250 °F.

The results of the three fire tests in terms of the ASTM E119 Conditions of Acceptance are summarized in **Table 7**.

**Table 7. Summary of Test Results ASTM E119 (Underwriters Laboratories, Inc., 2009)**

Test Assembly No.	Time of 250°F avg. temperature rise on surface of floor (min:sec)	Time of 325°F max. temperature rise on surface of floor (min:sec)	Flame passage through floor (min:sec)	Collapse (min:sec)	Fire resistance rating (min)
1	*	*	26:00	30:08	26
2	12:30	11:15	11:45	13:06	11
3	10:45	5:00	11:30	13:20	5

**Notes:**

\* - This condition was not achieved during the fire test.

Other significant data obtained during the fire tests included observation of the conditions of the ceiling and floor surfaces, temperatures in the concealed space above the ceiling membrane and deflections of the floor and roof surfaces.

The finish rating and the load bearing capacity of Benchmark assemblies from the UL project and the three tested assemblies are summarized in **Table 8**.

**Table 8. Summary of Significant Events in Addition to ASTM E119 Conditions of Acceptance (Underwriters Laboratories, Inc., 2009)**

Test Assembly No.	Initial falling of ceiling material (More than 1 ft <sup>2</sup> ) (min:sec)	Average temperature on unexposed surface of ceiling at initial falling (°F)	Finish rating (min:sec)	Load bearing Capacity (min)
Benchmark1 <sup>1</sup>	No ceiling	No Ceiling	00:45	18
Benchmark2 <sup>2</sup>	16:00	559	12:15	25
Benchmark3 <sup>3</sup>	16:30	519	10:45	24
Benchmark4 <sup>4</sup>	23:30	605	15:30	45
Benchmark5 <sup>5</sup>	74:00**	1109	74:00**	80
1	17:15	646	13:00	24
2	No ceiling	No ceiling	00:15	10
3	No ceiling	No ceiling	00:30	5

\*\* - plaster ceiling in contact with furnace thermocouples at 51 minutes

**Notes:**

1 – Benchmark 1 data represents a combustible floor-ceiling assembly of typical unprotected legacy construction (2 x 10) without a ceiling

- 2 – Benchmark 2 data represents a combustible floor-ceiling assembly of typical modern construction of parallel chord truss with glued connections with a ½ thick regular gypsum board ceiling
- 3 – Benchmark 3 data represents a combustible floor-ceiling assembly of typical modern construction of parallel chord truss with steel gusset connections with a ½ thick regular gypsum board ceiling
- 4 – Benchmark 4 data represents a combustible floor-ceiling assembly of typical protected legacy construction (2 x 10) with a ½ inch regular gypsum board ceiling
- 5 – Benchmark 5 data represents a combustible floor-ceiling assembly of typical protected legacy construction (2 x 10) with a ¾ inch metal lath and plaster ceiling

**Review and Comment:** From the previous 2008 UL project, it was determined that the load bearing capacity of an unprotected combustible floor-ceiling assembly representing typical unprotected legacy construction (2 x 10) without a ceiling was 18 minutes. The time duration was based upon the performance of the assembly when exposed to the time-temperature curve defined in Standard ASTM E119. This was defined as the benchmark (Benchmark 1) fire resistance performance of traditional exposed lumber construction typically found in lowest floor above basement or crawl spaces.

- The fire containment performance of Test Assembly 1 representing modern steel gusset truss construction with a ceiling with penetrations was 6 minutes more than the benchmark performance
- The fire containment performance of Assembly 2 representing unprotected modern glued truss construction was 8 minutes less than the benchmark performance.
- The fire containment performance of Assembly 3 representing unprotected modern steel gusset construction with stairwell framing was 13 minutes less than the benchmark performance.
- Similar to previous results, unprotected wood assemblies exhibited a reduced load bearing capacity when significantly weakened by fire. The unprotected engineered wood assemblies upon combustion contributed significant fuel loads to the experimental fires raising corresponding temperatures above the standardized ASTM E119 time temperature curve.
- Unprotected engineered assemblies exhibit a reduced load bearing capacity when significantly weakened by fire as evident in a comparative analysis comparing test standards similar to ASTM E119 with standards such as the ISO 834:1 Fire-resistance tests – Elements of building construction.

## **4.2. Fire Endurance Performance of Unprotected Assemblies – Standardized ASTM E-119 Furnace Testing**

### **4.2.1. National Engineered Lightweight Construction Fire Research Project Report: Literature Search and Technical Analysis –Fire Protection Research Foundation, 1992.**

**Conducting Agency:** In October of 1992 the National Fire Protection Research Foundation published, “National Engineered Lightweight Construction Fire Research Project Report: Literature Search and Technical Analysis” (Grundahl, 1992). The overall objective of the Fire Protection Research Foundation (FPRF) National Engineered Lightweight Construction Fire Research Project was to define the actual fire performance characteristics of engineered components.

**Report Series:** The components examined in this study include: metal plate connected (MPC) wood trusses, MPC metal-web wood trusses, pin-end connected steel-web wood trusses, wooden I -joists, solid-sawn (e.g., 2 x 10) wood joists, composite wood joists, steel bar joists, and steel C joists. The following is a list of the testing citing for Standardized ASTM E-119 furnace testing conducted with modified loading conditions respective of the structural elements being examined for this research project.

**Table 9. . Standardized ASTM E-119 Furnace Testing (Grundahl, 1992)**

Test	Structural Member	Spacing	Structural Failure (min:sec)	Loading (psf) - % Design Stress
FM FC 209 (Factory Mutual Research, 1974)	2 x 10; 23/32" ply. w/vnl	24 in. o.c.	13:34	62.1 (100%)
FM FC 212 (Factory Mutual Research , 1974)	2 x 10; 23/32"ply. w/cpt	24 in. o.c.	12:06	62.4 (100%)
NBS 421346 (Son B. , Fire Endurance Tests of Unprotected Wood-Floor Construcitons for Single Family Residences: NBSIR 73-263, 1973)	2 x 10; 1/2" & 5/8" ply.	16 in. o.c.	11:38	63.7 (100%)
FPL (R.H. White, 1983)	2 x 10; 23/32" ply.	16 in. o.c.	6:12	79.2 (100%)
FPL (R.H. White, 1983)	2 x 10; 23/32" ply.	16 in. o.c.	6:48	79.2 (100%)
FPL (R.H. White, 1983)	2 x 10; 23/32" ply.	16 in. o.c.	7:30	79.2 (100%)
FPL (R.H. White, 1983)	2 x 10; 23/32" ply.	16 in. o.c.	5:30	79.2 (100%)
FPL (R.H. White, 1983)	2 x 10; 23/32" ply.	16 in. o.c.	6:18	79.2 (100%)
FM FC 250 (Factory Mutual Research , 1977)	12 in. MPCT; 3/4" ply.	24 in. o.c.	10:12	60.0 (100%)
FM FC 208 (Factory Mutual Research , 1974)	7¼ in. Steel C-joist; 23/32"ply. w/vnl	24 in. o.c.	7:30	69.8 (100%)
FM FC 211 (Factory Mutual Research, 1974)	7¼ in. Steel C-joist; 23/32"ply. w/cpt	24 in. o.c.	5:12	69.8 (100%)

**Review and Comment:** The FPRF report and the source literature were reviewed for testing conducted prior to 1992. The majority of the tests conducted were of unprotected dimensional lumber floor assemblies. A summary of these tests results is shown in **Table 9**.

## 5. Experimental Description

Seven floor assemblies were tested utilizing a standard test method to determine their structural performance when exposed to fire conditions. The details of the seven experiments are summarized in Table 10. Floor system, floor system protection method and loading were varied to provide results that complement the grant projects objectives and fill voids in previous research. The Experimental method followed, materials used, construction methods utilized, structural load methods and the instrumentation used are documented in this section.

**Table 10 - Summary of Experiments**

<b>Experiment</b>	<b>Supports</b>	<b>Loading</b>
1	Engineered I Joists with Openings	Modified
2	Engineered Wood and Metal Hybrid Trusses	Modified
3	Engineered I Joists w/ Intumescent Coating	Modified
4	Engineered I Joists	100 % of the Design Load
5	Engineered I Joists w/ Fire Retardant Coating	Modified
6	Nominal 2 in by 10 in Dimensional Lumber	100 % of the Design Load
7	Legacy Nominal 2 in by 8 in Dimensional Lumber	100 % of the Design Load

### 5.1. Experimental Method

The fire experiments were conducted in accordance with the Standard, Fire Tests of Building Construction and Materials, ASTM E119 (ANSI/UL 263, 13th Edition, April 4, 2003). The ASTM E119 test method provides a comparative benchmark for the fire resistance of building assemblies. The temperatures in the test chamber (floor furnace) are representative of a fully developed fire in most buildings. This fire condition does not and cannot replicate all fire situations in buildings.

The floor furnace at UL's laboratory in Northbrook, IL was utilized to conduct the experiments (Figure 5). The floor furnace exposes a 14 ft. by 17 ft. floor system to the standard time temperature curve (Table 11). The standard states the transmission of heat through the specimen during the classification period shall not have raised the average temperature on its unexposed surface to more than 250°F above its initial temperature or raised any one point on its unexposed surface more than 325°F. This criterion was measured however the test was conducted until the floor system collapsed into the furnace before termination and suppression.

**Table 11. Time Temperature Requirements****Figure 5. UL Floor furnace**

<b>Time</b>	<b>Temperature</b>
5 min	1000 °F
10 min	1300 °F
30 min	1550 °F
1 hour	1700 °F
2 hours	1850 °F
4 hours	2000 °F
8 hours	2300 °F



## 5.2. Experimental Assembly Materials and Construction Details

Several different materials were used to construct the assemblies. The assemblies in which these materials were used are identified in Table 12 and described in detail below. The floor-ceiling assemblies were installed in the test frame in accordance with practices and methods outlined in the standard.

**Table 12 - Identification of Materials used in Multiple Assemblies**

Material	Assembly Number						
	1	2	3	4	5	6	7
Engineered I Joists with Openings	Yes	No	No	No	No	No	No
Engineered Wood and Metal Hybrid Trusses	No	Yes	No	No	No	No	No
Engineered I Joists	No	No	Yes	Yes	Yes	No	No
Nominal 2 x 10 Solid Lumber	No	No	No	No	No	Yes	No
Nominal 2 x 8 Solid Legacy Lumber	No	No	No	No	No	No	Yes
Bearing Plates – 2 by 4	Yes	Yes	Yes	Yes	Yes	No	No
Rimboard – 1-1/8 in. Thick	Yes	Yes	Yes	Yes	Yes	No	No
Subflooring (OSB)	Yes	Yes	Yes	Yes	Yes	Yes	Yes
Intumescent Coating	No	No	Yes	No	No	No	No
Fire Retardant Coating	No	No	No	No	Yes	No	No

**Engineered I Joists with Openings** – The nominal 16 in. engineered I Joist measured 16 in. tall and were cut to a length of 13 ft. 7-3/4 in. The chords consisted of 3-1/2 in. wide by 1-3/8 in. deep solid lumber with multiple sections finger jointed and glued together to make the full lengths. The web consisted of 5/8 in. thick oriented strand board and was provided with 6 openings of various sizes. The average weight of the I Joists was 63.43 lb. (Figure 6).



**Figure 6 - Engineered Castellated I Joist**

**Engineered Wood and Metal Hybrid Trusses**– The nominal 14 in. deep engineered trusses measured 14 in tall and were cut to a length of 13 ft. 8 in. The top and bottom chords consisted of 2-1/2 in. wide by 1-1/2 in. deep solid lumber with multiple sections finger jointed and glued together to make the full lengths. The web consisted of metal gusseted U shaped steel web members measuring 0.04 in. thick with 0.34 in. long teeth projecting perpendicular to the plane of the web member. The triangular shaped steel web members were located on both sides of the top and bottom wood chords and measured 14 in. tall by 29 in. long. At the end of the trusses, the trimmable ends consisted of the top and bottom chords with 1/2 in. thick oriented strand board webbing. The average weight of the trusses was 42.04 lb. (Figure 7).



**Figure 7 - Engineered Wood and Metal Hybrid Trusses**

**Engineered I- Joists** – The nominal 12 in. engineered I Joists measured 11-7/8 in. tall and were cut to a length of 13 ft. 8 in. The chords consisted of 2-1/2 in. wide by 1-1/2 in. deep solid lumber with multiple sections finger jointed and glued together to make the full lengths. The web consisted of 3/8 in. thick oriented strand board. The average weight of the I Joists was 38.4 lb. (Figure 8).



**Figure 8 - Engineered Wood I Joists**

**Nominal 2 by 10 Solid Lumber** – The nominal 2 in. by 10 in. dimensional lumber measured 9-1/8 in. by 1-1/2 in.

**Nominal 2 by 8 Solid Legacy Lumber** – The nominal 2 in. by 8 in. legacy dimensional lumber measured 7-1/2 in. by 1-5/8 in. This lumber was reclaimed from a structure that was constructed circa 1940.

**Bearing Plate (2 by 4)** – The nominal 2 in. by 4 in. dimensional lumber measured 1-1/2 in. by 3-1/2 in.

**Subflooring (OSB)** – The nominal 48 in. by 96 in. tongue and groove subflooring measured 47-1/2 in. by 96 in. by 3/4 in. thick.

**Intumescent Coating** – Spray applied intumescent coating which was UL Classified for Fire Resistance for multiple applications when applied to steel sections. This product is currently not designed for use on wood.

**Fire Retardant Coating** – Spray applied fire retardant coating. This product is designed to be applied on wood.

**Rimboard (OSB)** – The nominal 1-1/8 in. OSB measured 1-1/8 in. thick by 16 in, 14 in. and 12 in. deep with respect to the structural members used.

The assemblies for all of the experiments were constructed in the following manner. Nominal 2 in. by 4 in. structural grade wood bearing plates were placed on top of the steel angles of the test frame. The joists were placed on the wood bearing plates and spaced 24 in. on center (OC) starting at the East-West centerline of the assembly. The joists were fire stopped with 12 ft. long pieces of rimboard or dimensional lumber for Experiments 6 and 7. At the North and South ends of the assembly, two additional wood

joists, not in the field of the fire for the test, were placed on the North and South edges of the assembly over the vermiculite concrete used to protect the test frame, in order to support the wood tongue and groove subfloor. The average bearing at each end of the joist was 2-3/8 in. The rimboard was secured to the bearing plate using No. 16d coated nails spaced 12 in OC. The joists were fastened to each bearing plate and rimboard with three No. 10d coated sinker nails, two of which were located on the bottom of the joist on each side of the bottom chord and the third was toe nailed through the top chord of the joists.

The nominal 8 ft by 4 ft tongue and groove subfloor sheets were laid perpendicular to the joists. A 1/4 in. bead of adhesive was placed on the top flange of each joist and a 1/8 in. bead of adhesive was placed on the tip of the tongue and groove connection prior to sliding the subfloor panels together and set in place. The subfloor panels were secured in place with 1-7/8 in. long ring shank underlayment nails spaced 6 in. on center at the edges of the panels and 12 in. on center in the field of each sheet.

After Assembly 3 was constructed, the intumescent material was sprayed applied to the entire exposed surface of the assembly including the subfloor and all exposed surfaces of the I Joists. The material thickness was taken after each coat of material was applied. Approximately 20 mils of material was applied per coat. The final thickness of material measured approximately 65 mils thick. The material was applied by a trained professional to the specifications obtained from the manufacturer of the product.

After Assembly 5 was constructed, the fire retardant coating was sprayed applied to the entire exposed surface of the assembly including the subfloor and all exposed surfaces of the I Joists. The material thickness was taken after the coat of material was applied. Approximately 15 mils of material was applied in a single coat. The material was applied by the manufacturer to their specifications.

### **5.3. Structural Load**

Two different load configurations were utilized during this experimental series. Assemblies 1, 2, 3 and 5 were loaded with a uniform load of 40 lb/ft<sup>2</sup> applied to the South and West edges of the assembly. The assembly was divided into quarters by length and width and the loading was positioned over the Western and Southern quarters of the assembly. In addition to the uniform load, two 300 lb. mannequins were located 24 inches North and South of the East-West centerline of the assembly, at the center of the span. One mannequin was intended to simulate a standing firefighter and the load was distributed over a square foot base. The other mannequin was intended to simulate a crawling firefighter and the load was distributed through the hands and knees (Figure 9). Drawings showing the floor assembly loading are located in Appendix A.

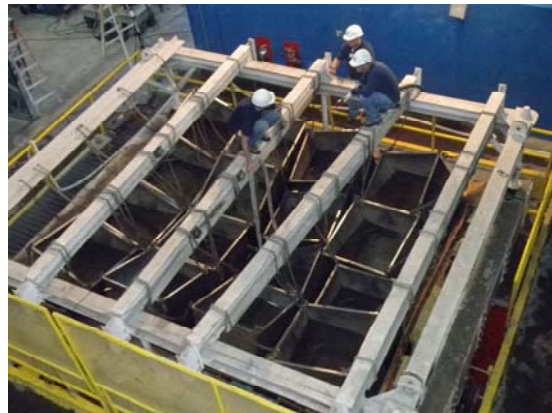

**Figure 9 - Loading of Assemblies 1, 2, 3 and 5**

Assembly 4, 6 and 7 were loaded to 100% of the design load of the engineered I Joists and solid lumber. Sixteen steel tanks were filled with water and distributed evenly over the entire unexposed surface of the assembly (Figure 10 and Figure 11). Drawings showing the floor assembly loading are also located in Appendix A.



**Figure 10 - Steel Tanks Filled with Water**



**Figure 11 – Layout of Steel Tanks (Post Test)**

#### **5.4. Instrumentation**

Three types of instruments were utilized during these experiments, thermocouples, deflection transducers, and cameras. Location of instrumentation within the furnace and on the experimental samples is shown in Appendix A. The furnace chamber temperatures were measured with 16 thermocouples located 12 in. below the exposed surface of the experimental assembly. These furnace thermocouples are used to regulate the furnace temperature in order to follow the standard time temperature curve. Additional thermocouples were placed on the floor assembly.

The temperatures of the joists were measured with 20 thermocouples. Thermocouple numbers 16-25 were located on the bottom chord of the joists and thermocouple numbers 26-35 were located on the side of the joists mid depth facing North. The thermocouples were stapled to the joists.

The temperatures between the joists were measured with 20 thermocouples. Thermocouple numbers 36-45 were located between the joists at mid depth, and thermocouple numbers 46-55 were located between the joists on the bottom of the subfloor (Figure 12).

The temperatures on the unexposed surface were measured with 15 thermocouples and numbered 1-15. Each of the unexposed surface thermocouples was covered with a 6 by 6 in. dry ceramic fiber pad.

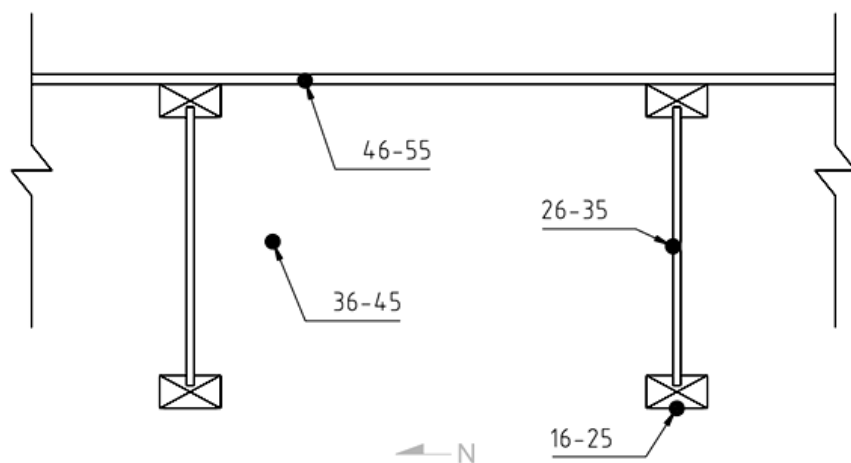

**Figure 12. Thermocouple Location Example**

The deflection of the assembly was measured with five electronic transducers.

There were a total of six camera views taken during the fire exposure period. One camera was positioned in the furnace recording the exposed surface of the assembly. Four other cameras recorded separate angles of the unexposed surface of the assembly and one infrared camera recorded the unexposed surface temperatures.

## 6. Experimental Results

The results for all of the experiments are detailed in this section. The furnace temperatures are plotted with the standard time-temperature curve. The pressure and oxygen concentration in the furnace are shown for each experiment. Observations made during the experiments are tabulated to detail fire conditions, smoke movement and collapse mechanisms. Average temperatures from all of the thermocouple locations are



plotted to examine the conditions in and out of the furnace. Deflection for each of the 5 measurement locations are plotted to examine the rate of deflection leading up to collapse. Finally, the collapse mechanism is discussed based of the post experiment documentation and photographs.

## 6.1. Experiment 1

Experiment 1 examined an engineered I-joist floor assembly with openings with the modified loading configuration (Figure 13 and Figure 14). The floor assembly failed at 8:10 after ignition. Observations made during the experiment of the exposed and unexposed sides of the floor assembly are detailed in Table 13. The average furnace temperature during the experiment began below the standard time temperature curve but exceeded it at approximately 2 minutes, when the floor system ignited and the temperatures remained above the curve for the duration of the experiment (Figure 15). The furnace pressure and oxygen concentration measured in the furnace are presented in Figure 16 and Figure 17 respectively. The pressure remained between -0.2 in.w.c. and 0.6 in.w.c. throughout the experiment. The oxygen concentration decreased to less than 2 % by 2 minutes and remained at or below that concentration until collapse. Pressure and oxygen concentrations are not specified in the standard test method.



Figure 13. Pre-test un-exposed side



Figure 14. Pre-test joist layout

**Table 13 – Observations for Test Assembly No. 1**

<b>Exp. Time, Min:Sec</b>	<b>Exposed (E) or Unexposed (U) Surface</b>	<b>Observations</b>
0:00	E	Fire Experiment Started
1:00	U	Smoke emitted from saddles.
1:30	U	Smoke emitted from entire west edge.
2:00	E	Joists ignited and smoke filled the furnace.
2:00	U	Crackling could be heard.
2:15	U	Smoke could be seen from subfloor joints.
2:45	U	Smoke increased.
3:00	E	Lower chords of joists charred
4:00	U	Smoke continued to increase
5:00	U	Floor vibration could be seen.
5:00	E	Visibility greatly reduced due to smoke in the furnace.
5:30	U	Floor vibration continued.
6:00	U	Floor vibration continued and more severe
7:00	U	Smoke increased and vibrations continued.
7:00	E	Joists deflected greatly, joist webs were deformed and began to burn through.
8:10	U	Crackling and structural failure occurred.
8:10	E	Structural failure occurred.
8:10	U	Gas off.

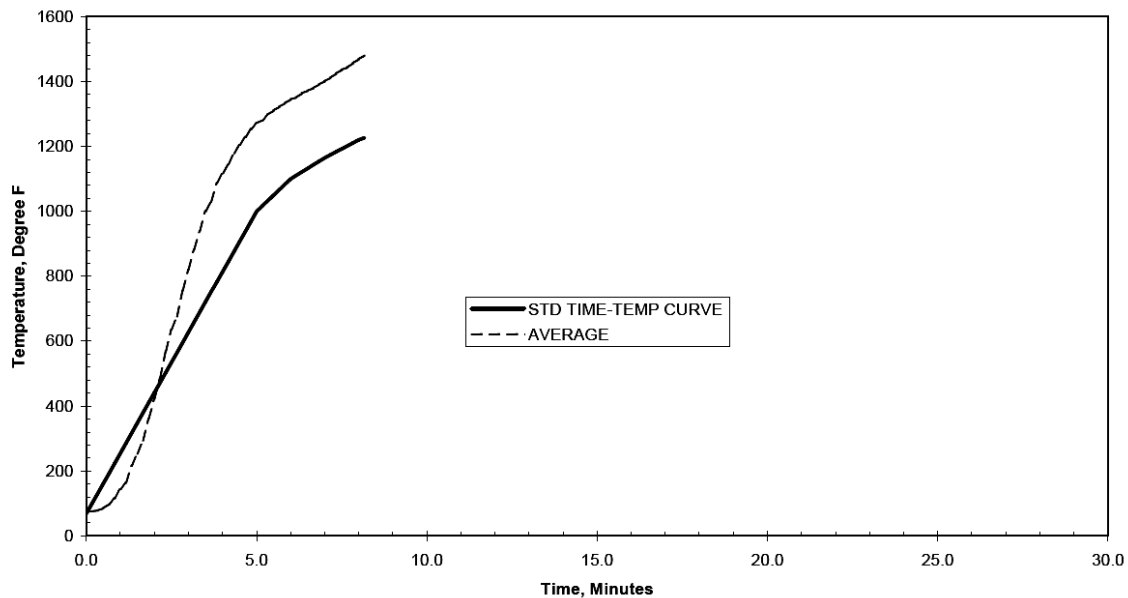
**Figure 15 - UL263 Standard Time Temperature Curve and Average Furnace Temperature vs. Time for Assembly No. 1**



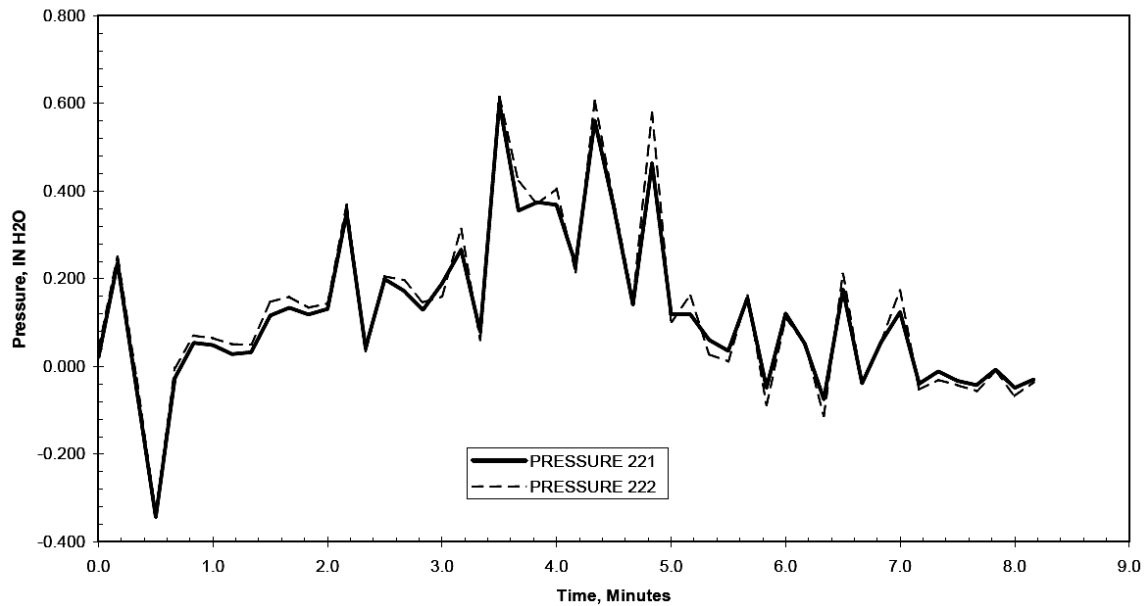

**Figure 16 - Furnace Pressure vs. Time for Assembly No. 1**

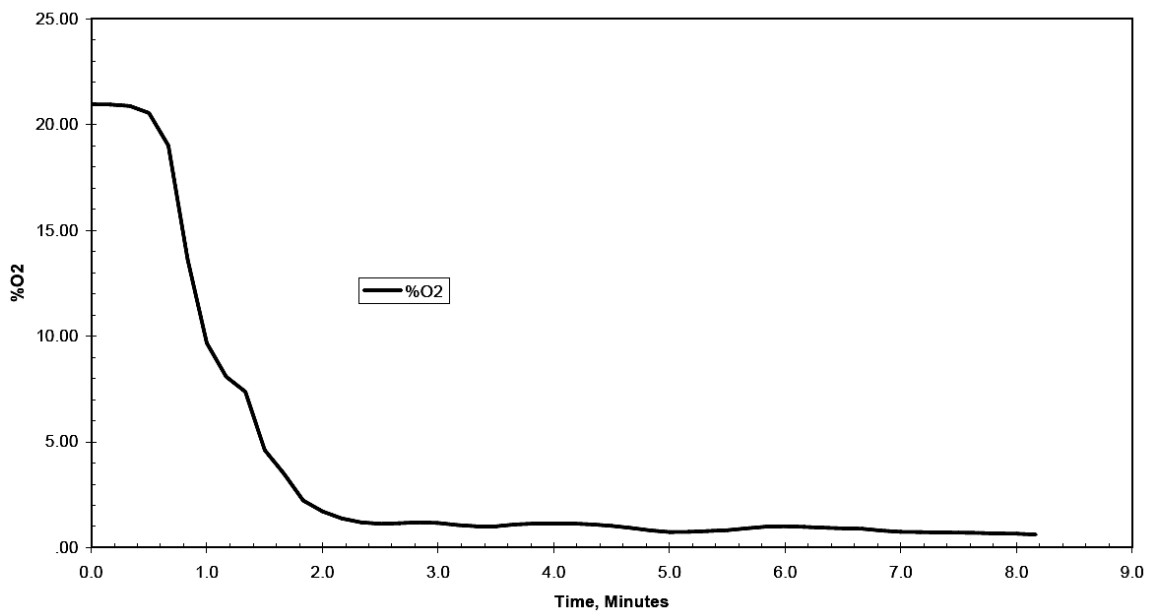

**Figure 17 - Oxygen Content vs. Time Oxygen Content vs. Time for Assembly No. 1**

The average temperatures recorded on and around the floor assembly are shown in Figure 18. The average and maximum temperatures of the bottom chords of the I Joists just before the moment of collapse (8 min 0 sec) were 1419°F and 1443°F respectively. The

maximum individual temperature was recorded by thermocouple number 22. The average and maximum temperatures of the sides of the I Joists just before the moment of collapse (8 min 0 sec) were 1422°F and 1464°F respectively. The maximum individual temperature was recorded by thermocouple number 32. The average and maximum temperatures of the mid depth between the I Joists just before the moment of collapse (8 min 0 sec) were 1414°F and 1434°F respectively. The maximum individual temperature was recorded by thermocouple number 44. The average and maximum temperatures of the sub floor between the I Joists just before the moment of collapse (8 min 0 sec) were 1418°F and 1437°F respectively. The maximum individual temperature was recorded by thermocouple number 47. The average and maximum temperatures of the unexposed surface just before the moment of collapse (8 min 0 sec) were 164°F and 205°F respectively. The maximum individual temperature was recorded by thermocouple number 9. The average temperature and maximum temperatures were plotted on Figure 19.

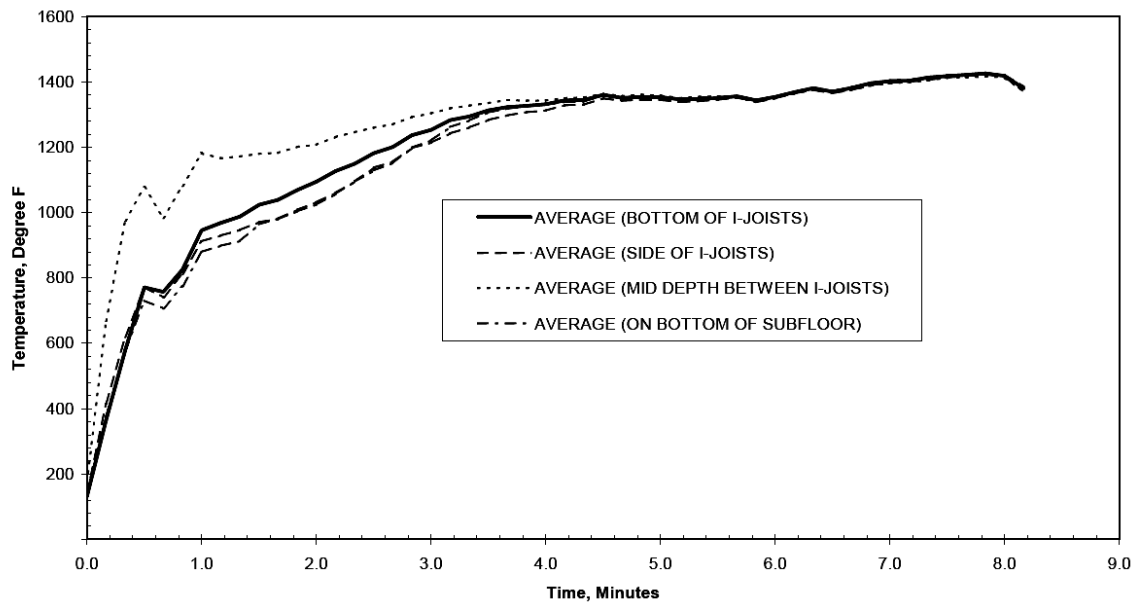
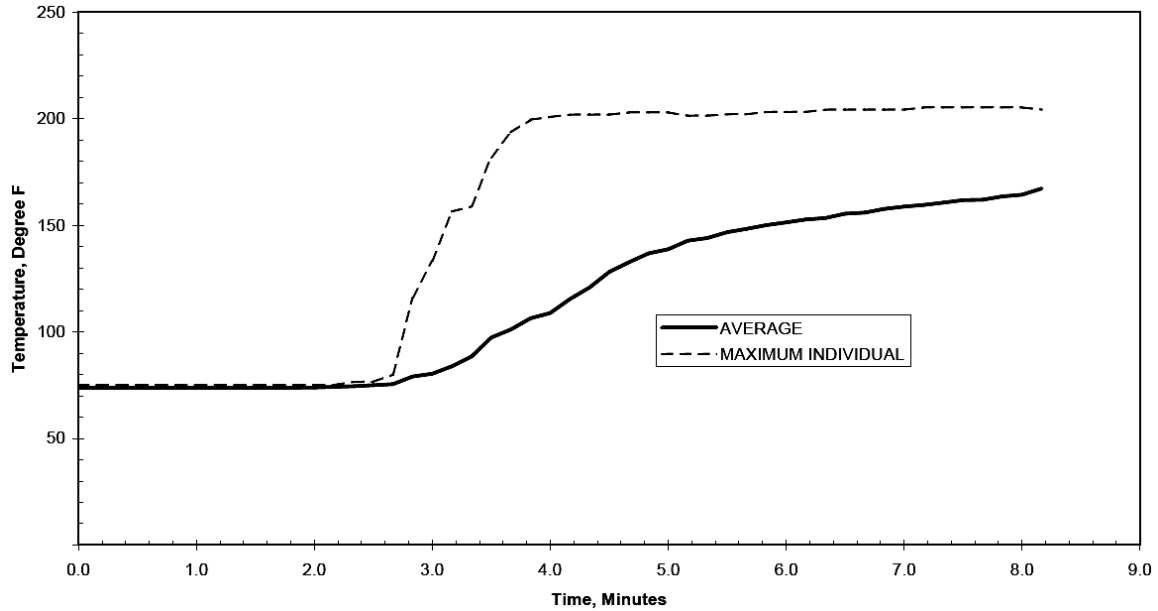

Figure 18 - Plot of Exposed Surface Temperatures vs. Time for Assembly No. 1



**Figure 19 - Plot of the Unexposed Surface Temperatures vs. Time for Assembly No. 1**

The deflection of the floor-ceiling assembly during the fire experiment is shown on Figure 20. The location of each deflection transducer can be seen in Appendix A. Measurable deflection began at approximately 2 minutes. A consistent deflection of approximately 3 in/min began at 5 minutes and continued until collapse. After the collapse of the floor system the fire was suppressed utilizing sprinklers mounted around the assembly and manual hose streams. Once the fire was suppressed, pictures were taken to document the condition of the floor system on the exposed and unexposed sides (Figure 21 through Figure 24). The failure mode for the engineered I-joists was due to burn-out of the web members.

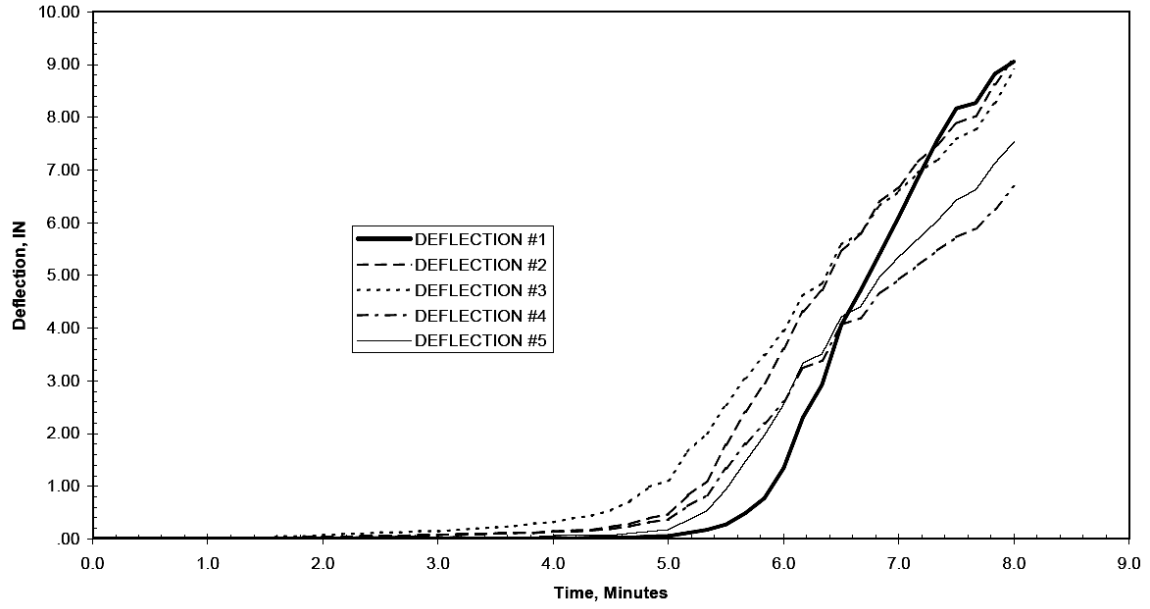

Figure 20 - Plot of Deflections vs. Time for Assembly No. 1



Figure 21. Unexposed side after removing load



Figure 22. Exposed side from North end



Figure 23. Joist with web burned away



Figure 24. Corner of furnace with some web remaining

## 6.2. Experiment 2

Experiment 2 examined an engineered wood and metal hybrid trusses floor assembly with the modified loading configuration (Figure 25 and Figure 26). The floor assembly failed at 5:30 after ignition. Observations made during the experiment of the exposed and unexposed sides of the floor assembly are detailed in Table 14. The average furnace temperature during the experiment began below the standard time temperature curve but exceeded it at approximately 2 minutes, when the floor system ignited and the temperatures remained above the curve for the duration of the experiment (Figure 27). The furnace pressure and oxygen concentration measured in the furnace are presented in Figure 28 and Figure 29 respectively. The pressure remained between -0.1 in.w.c. and 0.6 in.w.c. throughout the experiment. The oxygen concentration decreased to less than 2 % by 2.5 minutes and remained at or below that concentration until collapse.



Figure 25. Pre-test un-exposed side



Figure 26. Pre-test exposed side

Table 14 – Observations for Assembly No. 2

Exp. Time, Min:Sec	Exposed (E) or Unexposed (U) Surface	Observations
0:49	U	Crackling could be heard.
1:00	E	Truss chords blackened.
1:16	U	Smoke could be seen emitting from the perimeter saddles.
1:56	U	Increased frequency of cracking and more smoke was present.
2:00	E	Truss chords continued to blacken and subfloor began to blacken. Visibility inside furnace decrease
2:37	U	Smoke continued to increase and louder more frequent crackling could be heard.
3:00	U	Standing mannequin began to vibrate up and down. Burning embers emitted from South West edge.
3:51	U	Both mannequins began to vibrate up and down.
4:30	E	Webs separated from bottom chord at West edge close to South edge.
4:35	U	Continued vibrations of both mannequins.
5:00	E	Most of the web separated from bottom chord at west edge.
5:30	E/U	Structural Collapse. Gas off.

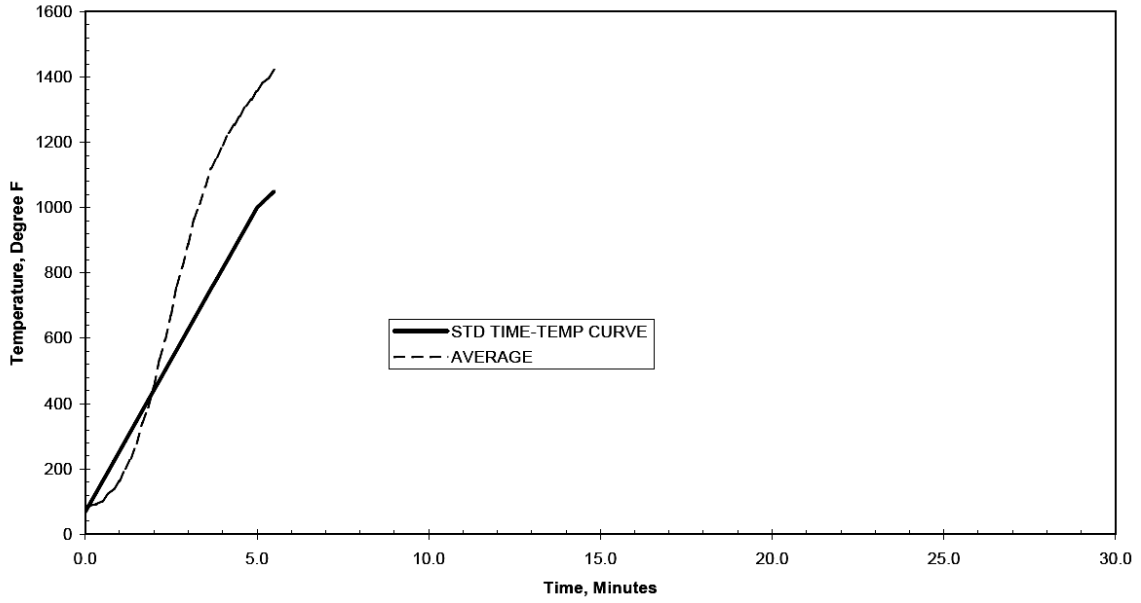

Figure 27 – UL263 Standard Time Temperature Curve and Average Furnace Temperature vs. Time for Assembly No. 2

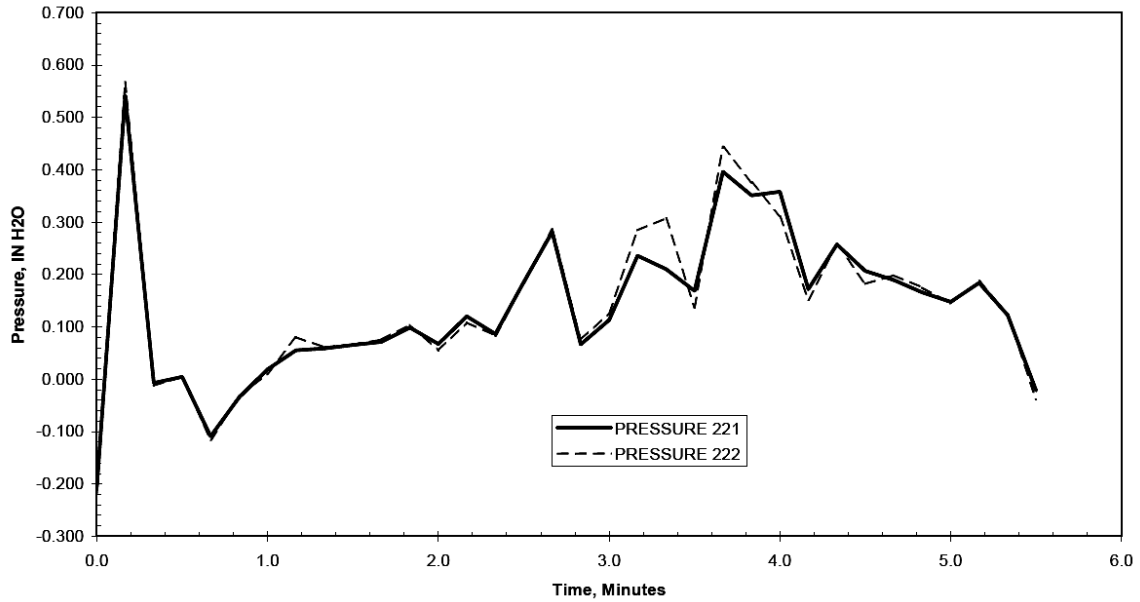
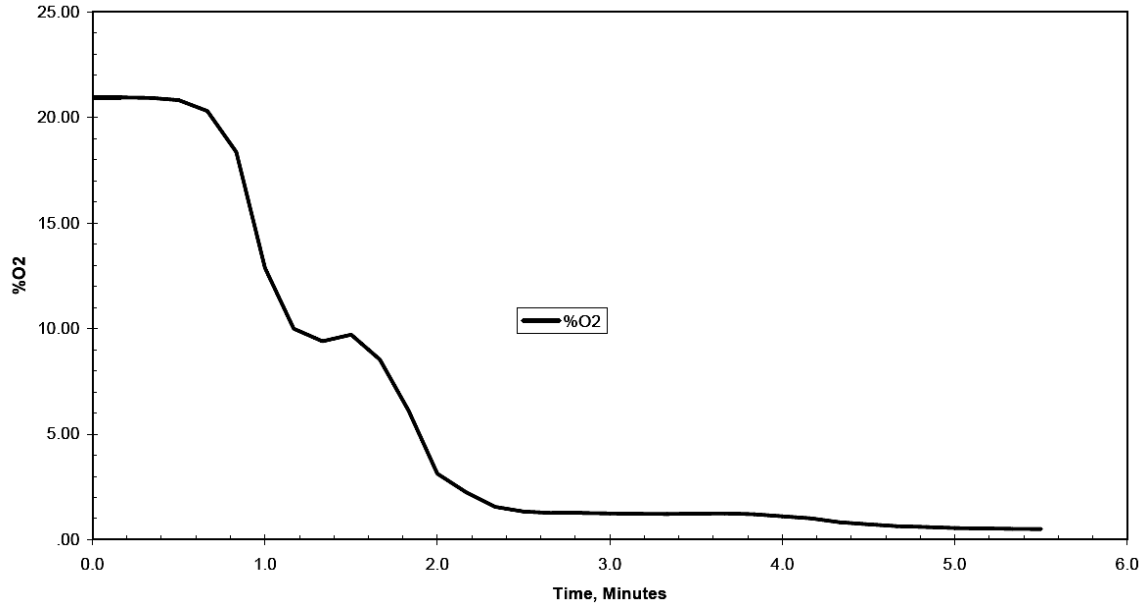

Figure 28 - Furnace Pressure vs. Time for Assembly No. 2



**Figure 29 - Oxygen Content vs. Time Oxygen Content vs. Time for Assembly No. 2**

The average temperatures recorded on and around the floor assembly are shown in Figure 30. The average and maximum temperatures of bottom chord of the I Joists just before the moment of collapse (5 min 20 sec) were 1424°F and 1463°F respectively. The individual temperature was recorded by thermocouple number 25. The average and maximum temperatures of the sides of the wood joists just before the moment of collapse (5 min 20 sec) were 1438°F and 1489°F respectively. The individual temperature was recorded by thermocouple number 35. The average and maximum temperatures of the mid depth between the wood joists just before the moment of collapse (5 min 20 sec) were 1425°F and 1468°F respectively. The individual temperature was recorded by thermocouple number 43. The average and maximum temperatures of the sub floor between the wood joists just before the moment of collapse (5 min 20 sec) were 1431°F and 1478°F respectively. The individual temperature was recorded by thermocouple number 53. The average and maximum temperatures of the unexposed surface just before the moment of collapse (5 min 20 sec) were 147°F and 202°F respectively. The individual temperature was recorded by thermocouple number 14.



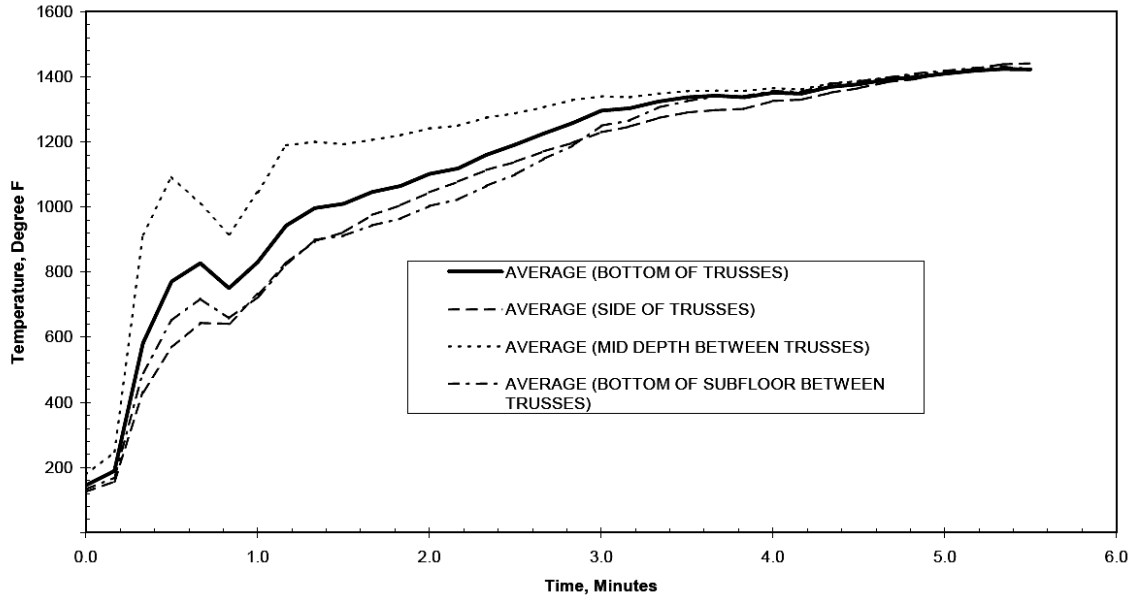

Figure 30 - Plot of Exposed Surface Temperatures vs. Time for Assembly No. 2

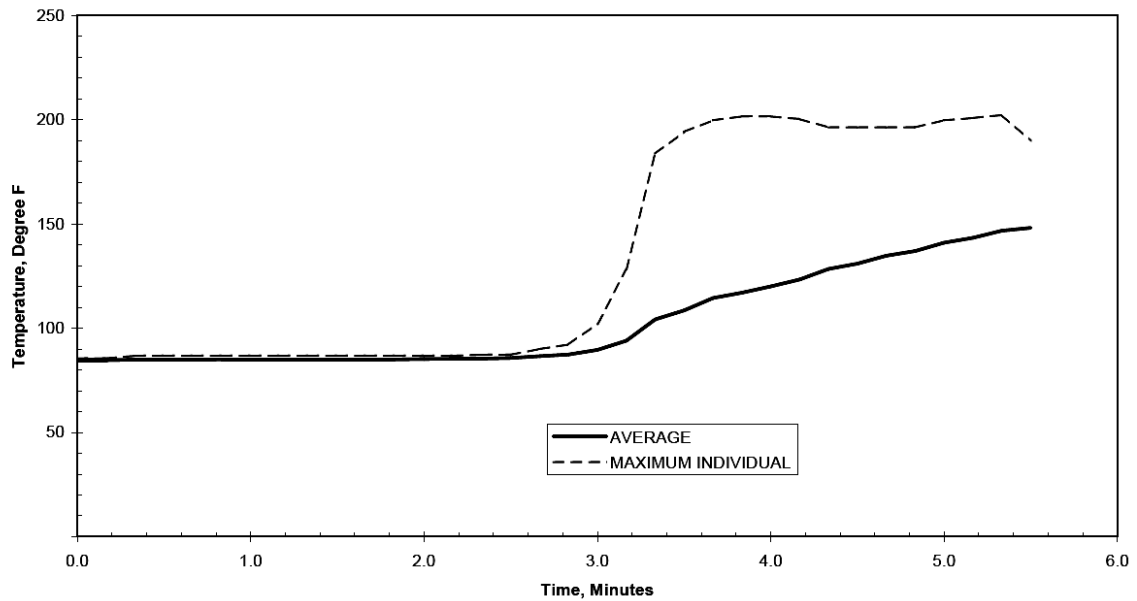

Figure 31 - Plot of Unexposed Surface Temperatures vs. Time for Assembly No. 2

The deflection of the floor-ceiling assembly during the fire experiment is shown on Figure 32. The location of each deflection transducer can be seen in Appendix A under Assembly 2. Measurable deflection began at approximately 1.5 minutes. A consistent deflection of approximately 3.6 in/min began at 3:40 and continued until collapse. After the collapse of the floor system the fire was suppressed utilizing

sprinklers mounted around the assembly and manual hose streams. Once the fire was suppressed, pictures were taken to document the condition of the floor system on the exposed and unexposed sides (Figure 33 through Figure 36). The failure mode for the engineered wood and metal hybrid trusses was due to charring and subsequent release of the connections attaching the metal web to the wood chord member.

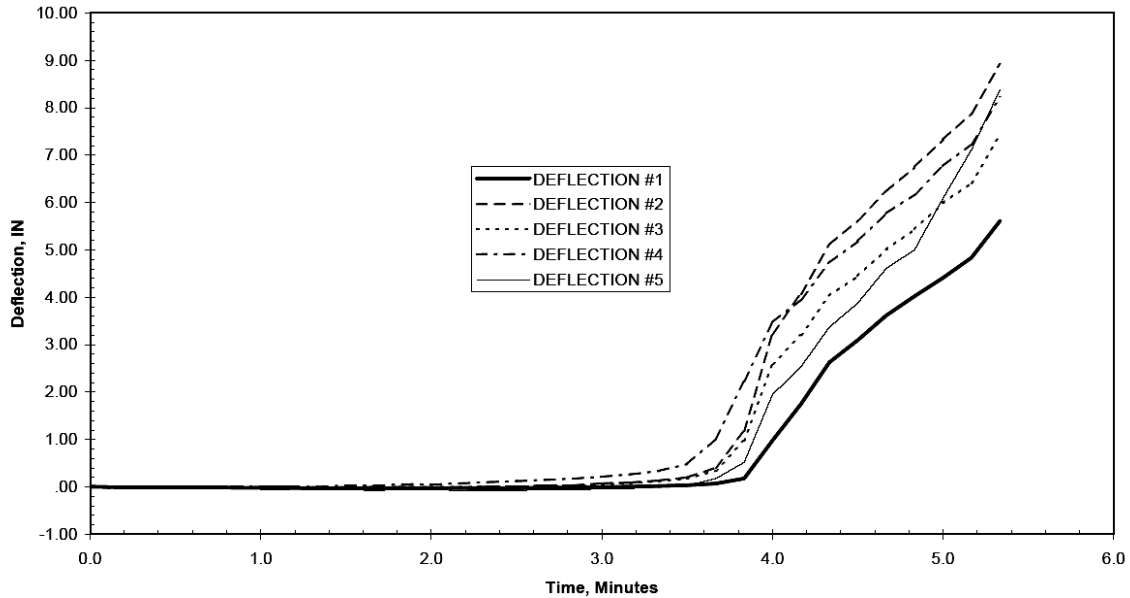

Figure 32 - Plot of Deflections vs. Time for Assembly No. 2



Figure 33. Unexposed side after collapse



Figure 34. Exposed side from North end



Figure 35. Joist with web disconnected



Figure 36. Close-up of char depth

### 6.3. Experiment 3

Experiment 1 examined an engineered I-joist floor assembly with a spray applied intumescent coating and the modified loading configuration (Figure 37 and Figure 38). The floor assembly failed at 17:50 after ignition. Observations made during the experiment of the exposed and unexposed sides of the floor assembly are detailed in Table 15. The average furnace temperature during the experiment began below the standard time temperature curve for approximately 2 minutes, but followed the curve closely for the duration of the experiment (Figure 39). The furnace pressure and oxygen concentration measured in the furnace are presented in Figure 40 and Figure 41 respectively. The pressure remained between -0.5 in. w.c. and 0.7 in. w.c. but fluctuated around 0 for most of the experiment. The oxygen concentration fluctuated and then decreased to less than 10 % by 8 minutes and remained at or below that concentration until collapse. Pressure and oxygen concentrations are not specified in the standard test method.



Figure 37. Pre-test un-exposed side



Figure 38. Pre-test exposed side

**Table 15 - Observations for Assembly No. 3**

<b>Exp. Time, Min:Sec</b>	<b>Exposed (E) or Unexposed (U) Surface</b>	<b>Observations</b>
1:15	U	Smoke could be seen from saddles around the edges of the assembly.
2:00	E	Intumescent coating began to blacken
2:40	U	Crackling could be heard and smoking ceased.
3:00	E	Furnace too dark to see inside.
4:00	U	Smoke started again from perimeter of assembly.
4:00	E	Joists completely black in color.
5:00	E	Significant flaming could be seen at North end of assembly in the first joist spacing.
6:00	E	Material has whitened and appears to have intumesced. Cracks in bottom chord could be seen.
6:30	U	Crackling and smoke continued.
6:30	E	Flaming at South end and flaming continued at North end.
8:00	E	Intumescent fall off could be seen.
8:30	U	Louder crackling could be heard.
9:00	E	Big section of material fall off from joists and subfloor could be seen.
10:00	U	More smoke was present.
10:00	E	Fall off continued over entire assembly.
11:00	E	Significant flaming continues from North and South joist spacings.
12:00	E	Periodic falloff of chunks of material continued over entire assembly
13:00	E	Furnace floor covered with intumescent falloff.
13:45	U	Louder crackling could be heard and even more smoke was present.
15:00	U	South edge of assembly began to visibly deflect.
15:00	E	More intumescent coating had fallen off of subfloor than joists.
15:10	U	Flaming was present along the south edge.
16:00	E	Significant deflection could be seen on the second joist from the south
17:30	E	Intumescent coating adhered surprisingly well to joists.
17:50	U	Structural Collapse.
17:50	E	Test Terminated.

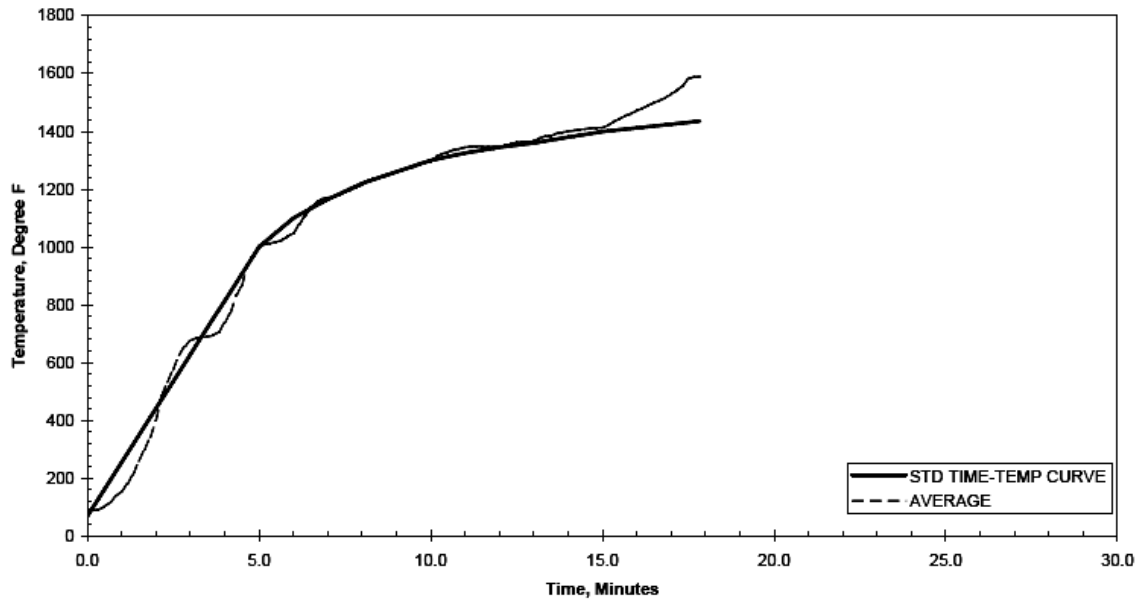

Figure 39 – UL263 Standard Time Temperature Curve and Average Furnace Temperature vs. Time for Assembly No. 3

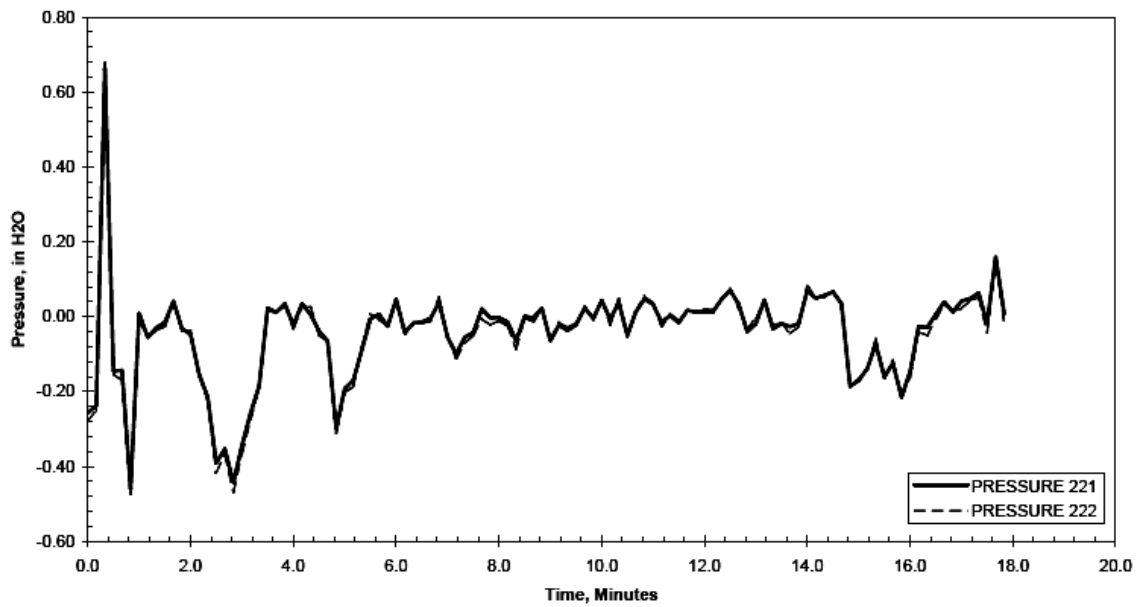
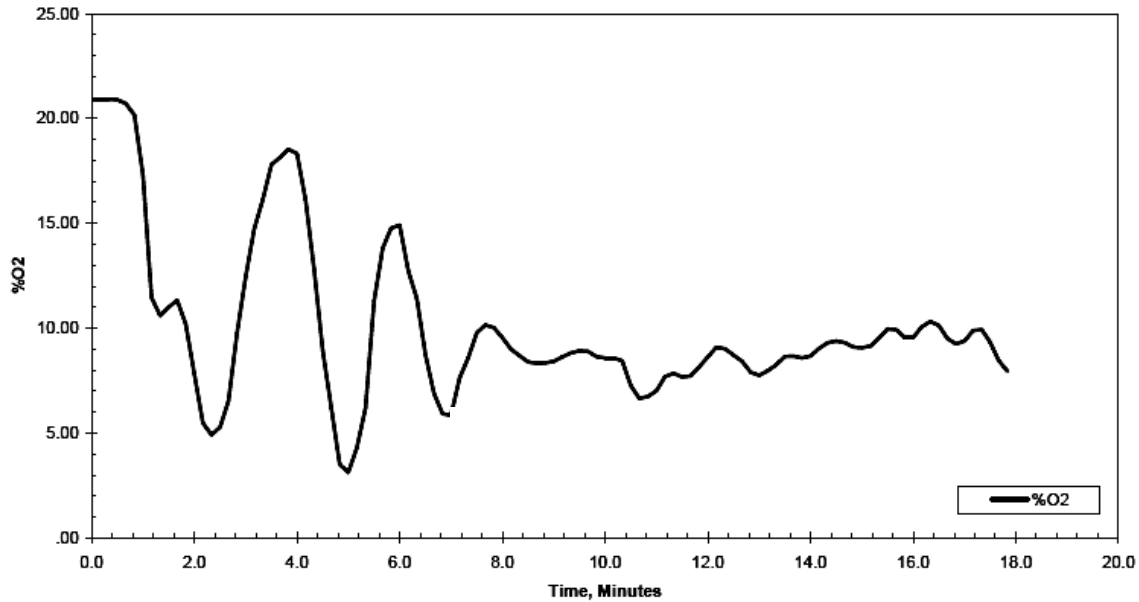

Figure 40 – Furnace Pressure vs. Time for Assembly No. 3



**Figure 41 – Oxygen Content vs. Time for Assembly No. 3**

A plot of the average temperatures in the area of the floor assembly can be seen on Figure 42. The average and maximum temperatures of the bottom chord of the wood I Joists just before the moment of collapse (17 min 40 sec) were 646°F and 1160°F respectively. The individual temperature was recorded by thermocouple number 25. The average and maximum temperatures of the sides of the wood I Joists just before the moment of collapse (17 min 40 sec) were 552°F and 608°F respectively. The individual temperature was recorded by thermocouple number 26. The average and maximum temperatures of the mid depth between the wood I Joists just before the moment of collapse (17 min 40 sec) were 1687°F and 1831°F respectively. The individual temperature was recorded by thermocouple number 39. The average and maximum temperatures of the sub floor between the wood I Joists just before the moment of collapse (17 min 40 sec) were 556°F and 727°F respectively. The individual temperature was recorded by thermocouple number 47. The average and maximum temperatures of the unexposed surface just before the moment of collapse (17 min 40 sec) were 185°F and 244°F respectively. The individual temperature was recorded by thermocouple number 14. A plot of these temperatures can be seen on Figure 43.

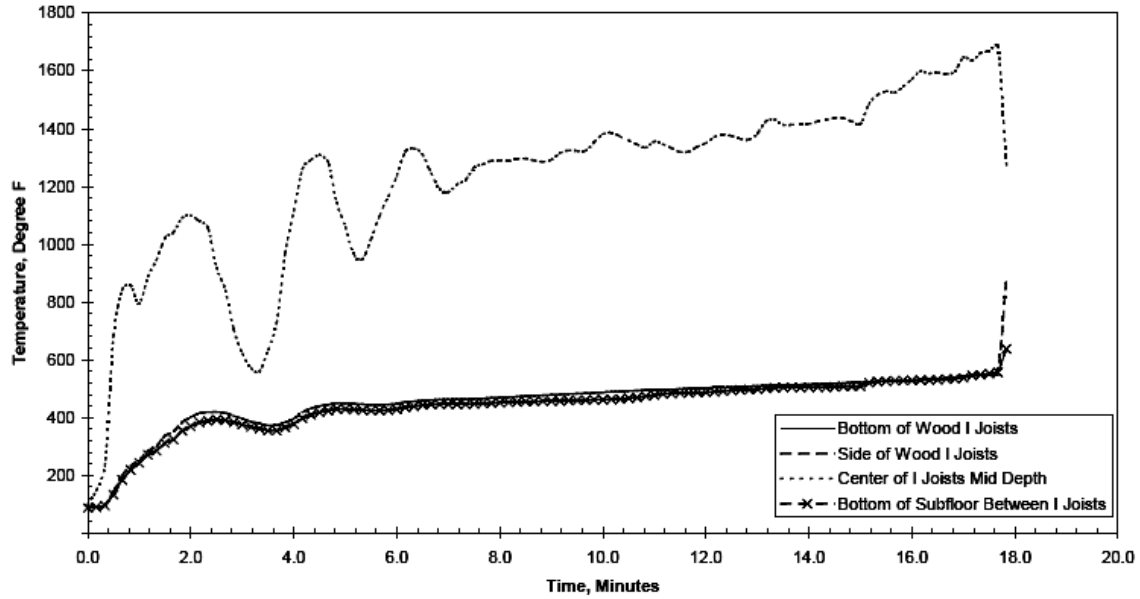

Figure 42 – Plot of Temperature Below Subfloor vs. Time for Assembly No. 3

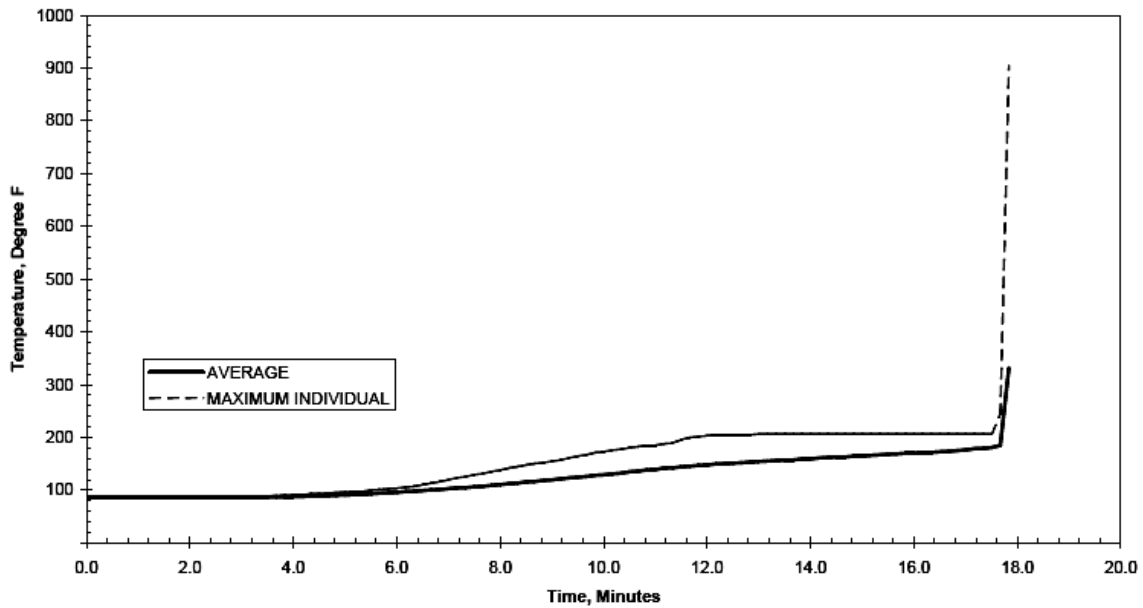

Figure 43 – Plot of Exposed Surface Temperatures vs. Time for Assembly No. 3

The deflection of the floor-ceiling assembly during the fire experiment is shown on Figure 44. The location of each deflection transducer can be seen in Appendix A under Assembly 3. Measurable deflection began at approximately 2 minutes. The most deflection occurred at the south end of the furnace, behind the standing mannequin. Just prior to collapse there was less than 2 in. of deflection in the center of the furnace but approximately 8 in. at the south end. After the collapse of the floor system the fire was

suppressed utilizing sprinklers mounted around the assembly and manual hose streams. Once the fire was suppressed, pictures were taken to document the condition of the floor system on the exposed and unexposed sides (Figure 45 through Figure 48). The failure mode for the engineered I-joists with the intumescent coating was burn away of the joists at the bearing condition until the joists weakened under the load.

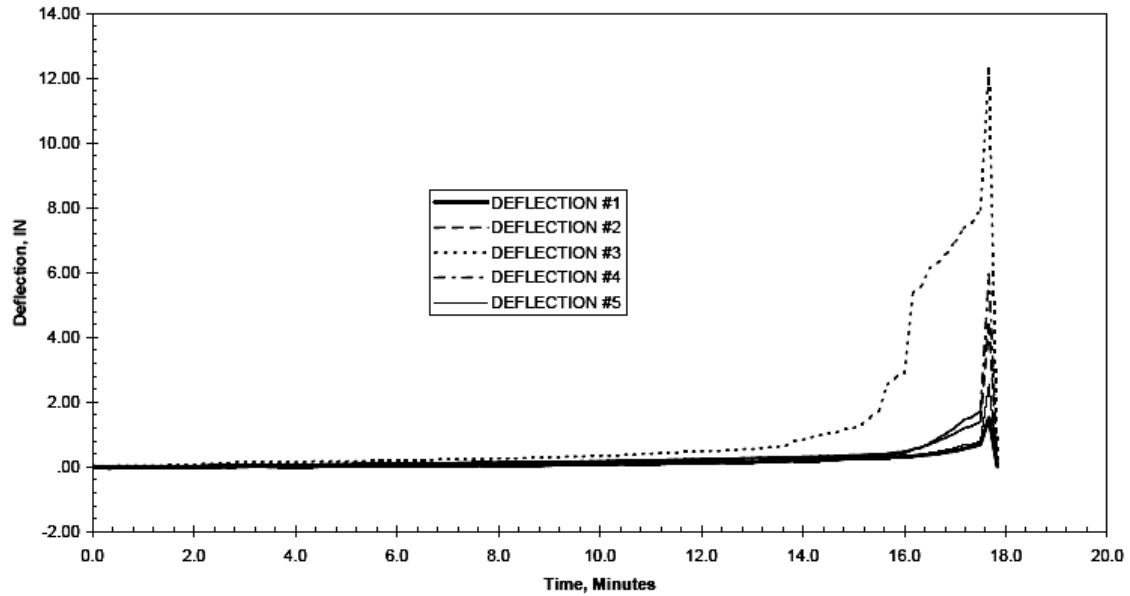

Figure 44 – Plot of Deflections vs. Time for Assembly No. 3



Figure 45. Unexposed side after collapse



Figure 46. Exposed side from North end





Figure 47. Joist with web burn through



Figure 48. Close-up of remaining web

#### 6.4. Experiment 4

Experiment 4 examined an engineered I-joist floor assembly with a standard floor loading configuration (Figure 37 and Figure 38). The total design load was calculated to be 75.9 lb/ft<sup>2</sup>. The floor assembly failed at 2:20 after ignition. Observations made during the experiment of the exposed and unexposed sides of the floor assembly are detailed in Table 16. The average furnace temperature during the experiment began below the standard time temperature curve but exceeded it at approximately 1.5 minutes, when the floor system ignited and the temperatures remained above the curve for the duration of the experiment (Figure 51). The furnace pressure and oxygen concentration measured in the furnace are presented in Figure 52 and Figure 53 respectively. The pressure remained between -0.2 in.w.c. and 0.7 in.w.c. but fluctuated around 0 for most of the experiment. The oxygen concentration decreased to less than 10 % by 1 minute and to below 5 % prior to 2 minutes and remained low until collapse.



Figure 49. Pre-test un-exposed side



Figure 50. Pre-test exposed side

Table 16 – Observations for Assembly No. 4

Exp. Time, Min:Sec	Exposed I or Unexposed (U) Surface	Observations
0:30	E	Bottom chord of I Joists began to char.
1:00	U	No changes occurred.
1:06	E	Entire subfloor and I Joists ignited
1:30	U	Crackling noises could be heard and smoke emitted from edges of assembly.
2:00	E	Entire assembly engulfed in flames.
2:00	U	Louder cracking noises could be heard.
2:20	U	Structural failure occurred. All loading equipment had fallen through the floor. Subfloor completely collapsed into the furnace and massive fire breached the unexposed surface.
2:20	E/U	Fire Test Terminated.

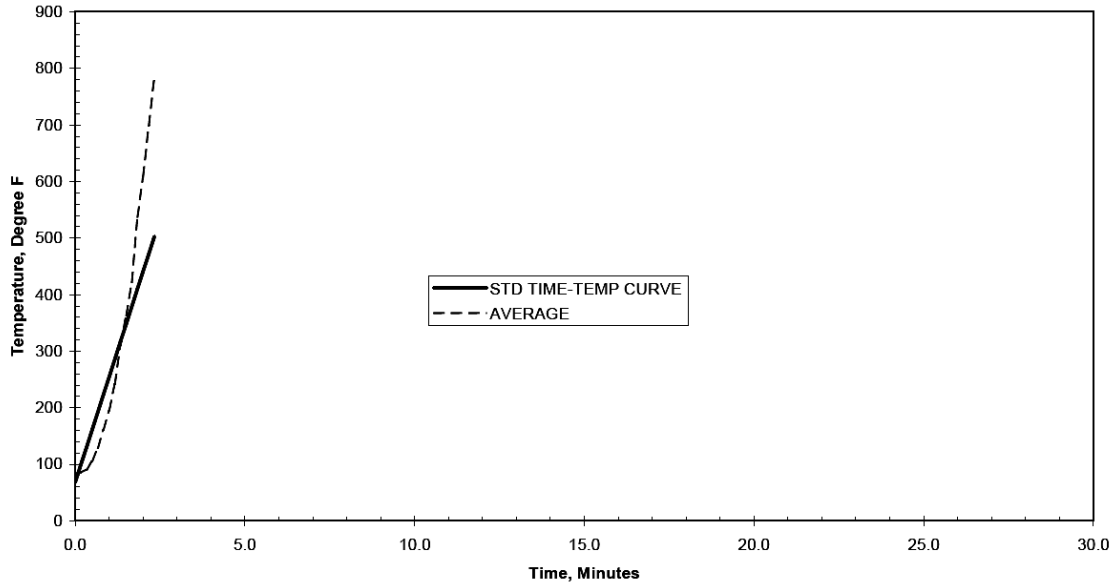

Figure 51 - UL263 Standard Time Temperature Curve and Average Furnace Temperature vs. Time for Assembly No. 4

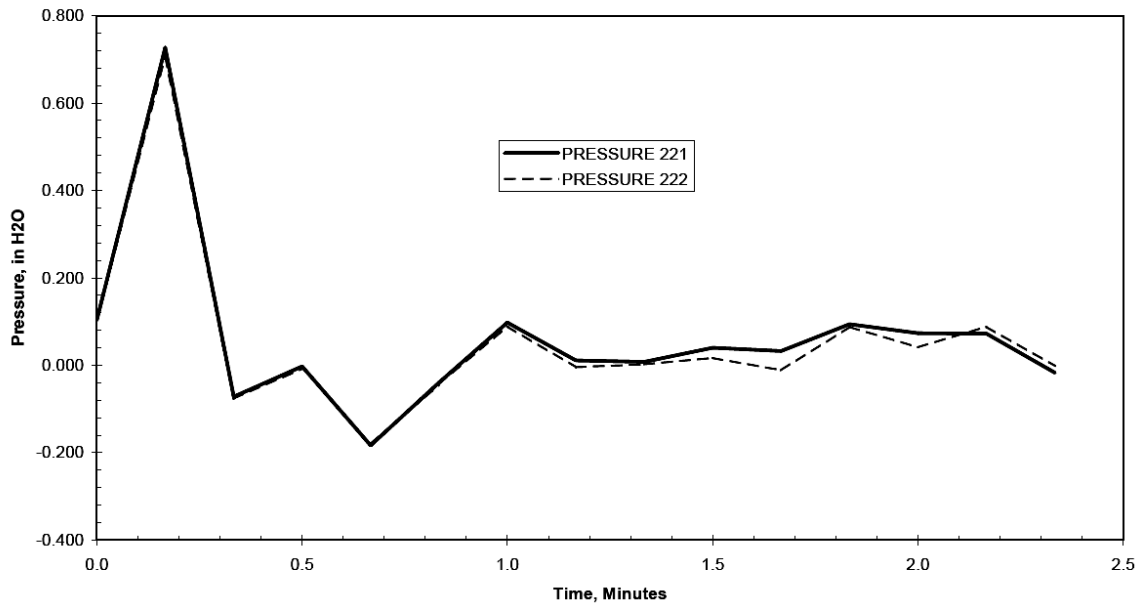
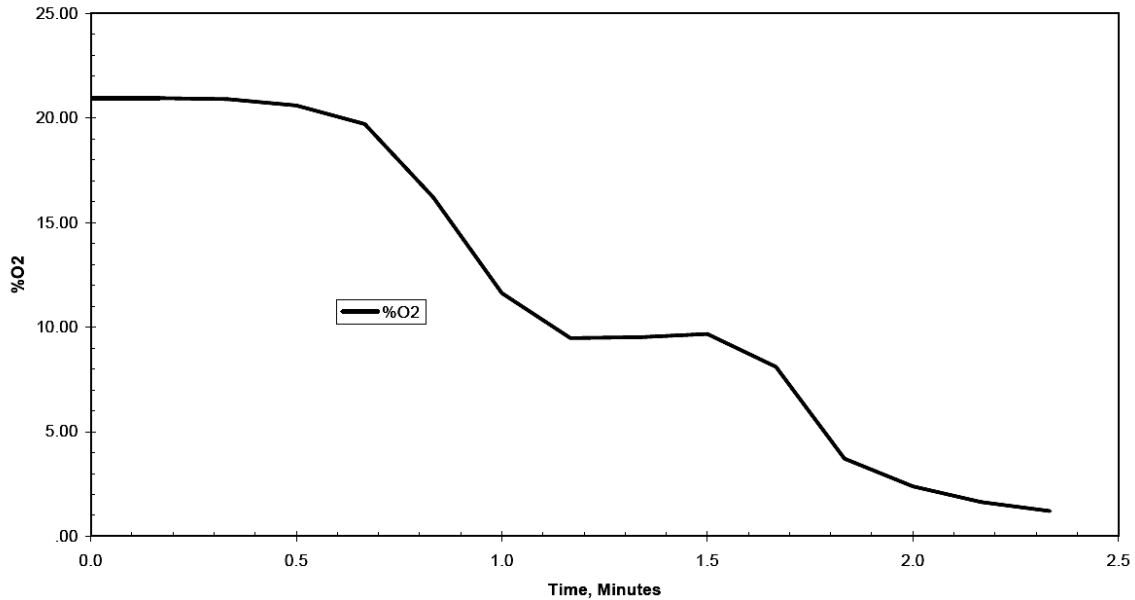

Figure 52 – Furnace Pressure vs. Time for Assembly No. 4



**Figure 53 - Oxygen Content vs. Time for Assembly No. 4**

A plot of the average temperatures in close proximity to the floor system can be seen on Figure 54. The average and maximum temperatures of the bottom chord of the I Joists just before the moment of collapse (2 min 10 sec) were 1253°F and 1342°F respectively. The individual temperature was recorded by thermocouple number 23. The average and maximum temperatures of the sides of the I Joists just before the moment of collapse (2 min 10 sec) were 1153°F and 1239°F respectively. The individual temperature was recorded by thermocouple number 35. The average and maximum temperatures of the mid depth between the I Joists just before the moment of collapse (2 min 10 sec) were 1341°F and 1434°F respectively. The individual temperature was recorded by thermocouple number 43. The average and maximum temperatures of the sub floor between the I Joists just before the moment of collapse (2 min 10 sec) were 1195°F and 1318°F respectively. The individual temperature was recorded by thermocouple number 52. The average and maximum temperatures of the unexposed surface just before the moment of collapse (2 min 10 sec) were 73°F and 77°F respectively. The individual temperature was recorded by thermocouple number 13. A plot of these temperatures can be seen on Figure 55.

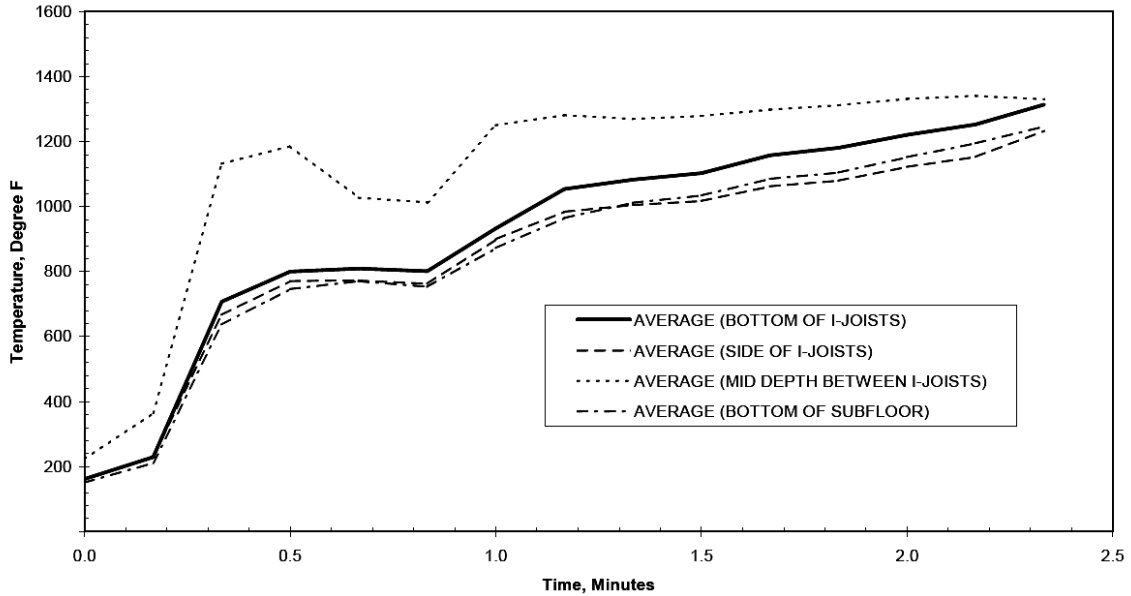

Figure 54 - Plot of Exposed Surface Temperatures vs. Time for Assembly No. 4

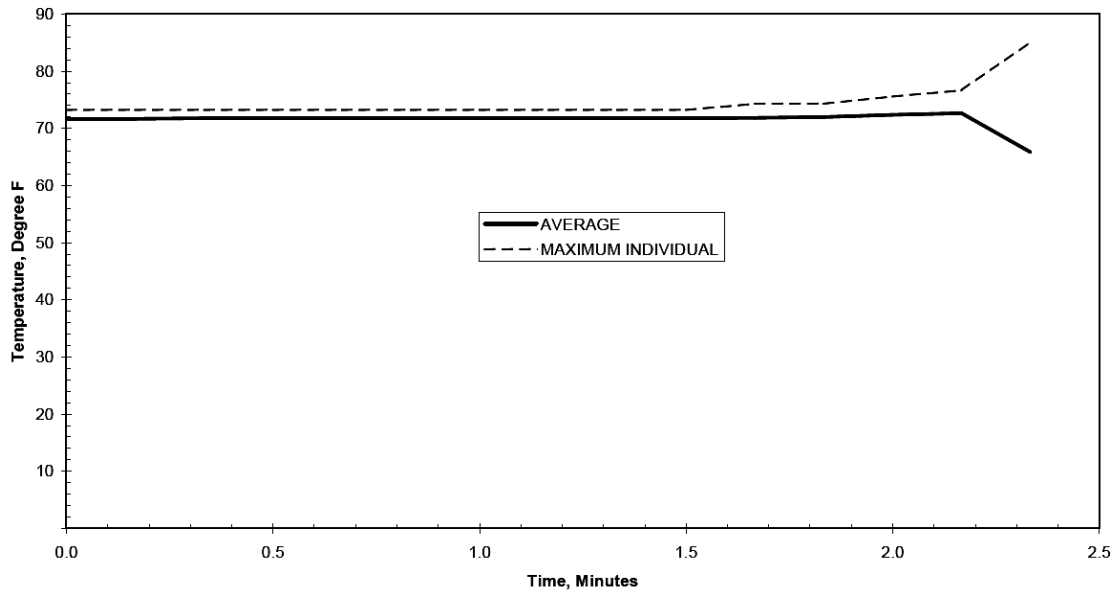

Figure 55 - Plot of Temperature of the Unexposed Surface vs. Time for Assembly No. 4

The deflection of the floor-ceiling assembly during the fire experiment is shown on Figure 56. The location of each deflection transducer can be seen in Appendix A under Assembly 4. Measurable deflection began at approximately 25 seconds. The deflection at all 5 measurement points were less than 1 in. prior to floor collapse. After the collapse of the floor system the fire was suppressed utilizing sprinklers mounted around the assembly and manual hose streams. Once the fire was suppressed, pictures were taken to

document the condition of the floor system on the exposed and unexposed sides (Figure 57 through Figure 60). The failure mode for the engineered I-joists was thermal decomposition or consumption of the web member of the joists.

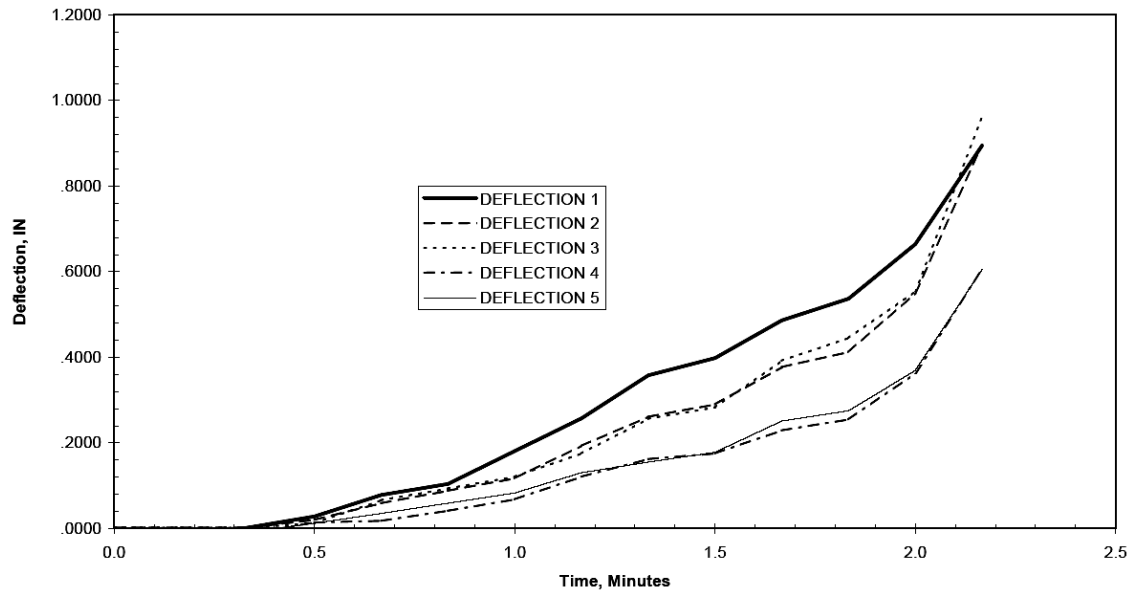

Figure 56 - Plot of Deflections vs. Time for Assembly No. 4

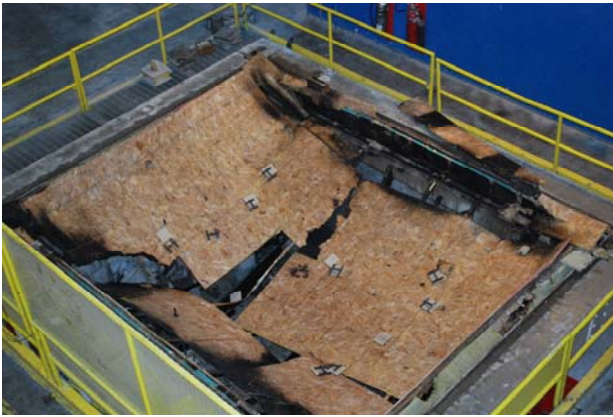

Figure 57. Unexposed side after collapse



Figure 58. Exposed side from North end





Figure 59. Joist with web burn through



Figure 60. Close-up of some remaining web

## 6.5. Experiment 5

Experiment 5 examined an engineered I-joist floor assembly with a spray applied fire retardant coating and the modified loading configuration (Figure 61 and Figure 62). The floor assembly failed at 8:40 after ignition. Observations made during the experiment of the exposed and unexposed sides of the floor assembly are detailed in Table 17. The average furnace temperature during the experiment followed the standard curve closely until approximately 6 minutes when the floor system was involved in flames (Figure 63). The furnace pressure and oxygen concentration measured in the furnace are presented in Figure 64 and Figure 65 respectively. The pressure remained between -0.3 in. w.c. and 0.6 in. w.c. but fluctuated around 0 for most of the experiment. The oxygen concentration fluctuated and then decreased to less than 5 % by 7 minutes and remained at or below that concentration until collapse. Pressure and oxygen concentrations are not specified in the standard test method.



Figure 61. Pre-test un-exposed side



Figure 62. Pre-test exposed side

Table 17 – Observations for Assembly No. 5

<b>Exp. Time, Min:Sec</b>	<b>Exposed (E) or Unexposed (U) Surface</b>	<b>Observations</b>
1:15	U	Crackling could be heard and smoke was present at West edge.
2:00	U	More frequent crackling could be heard.
2:00	E	To dark to seen in furnace.
3:10	U	Crackling and smoke ceased.
3:45	U	Crackling and smoke started again.
4:00	E	Material on joists began to lighten in color and started to crack.
4:15	U	More intense smoke and crackling was present.
4:45	E	Significant flaming could be seen from first two joist bays on the north end of the assembly.
5:10	U	Crackling continued.
6:00	U	Smoke from subfloor joints was present.
6:00	E	Joist orange in color and looked like charring wood.
6:45	E	Significant flaming over entire exposed surface.
7:00	U	Kneeling mannequin began to vibrate vertically.
7:30	U	Entire assembly began to deflect into the furnace.
7:30	E	Vision obscured by fall off material circulating throughout the furnace.
8:10	U	Larger vertical vibrations could be seen on both mannequins.
8:15	E	Noticeable deflection could be seen at the centerline of the assembly.
8:30	E	Joist webs started to burn through.
8:40	U	Structural failure.
8:40	E/U	Gas off.



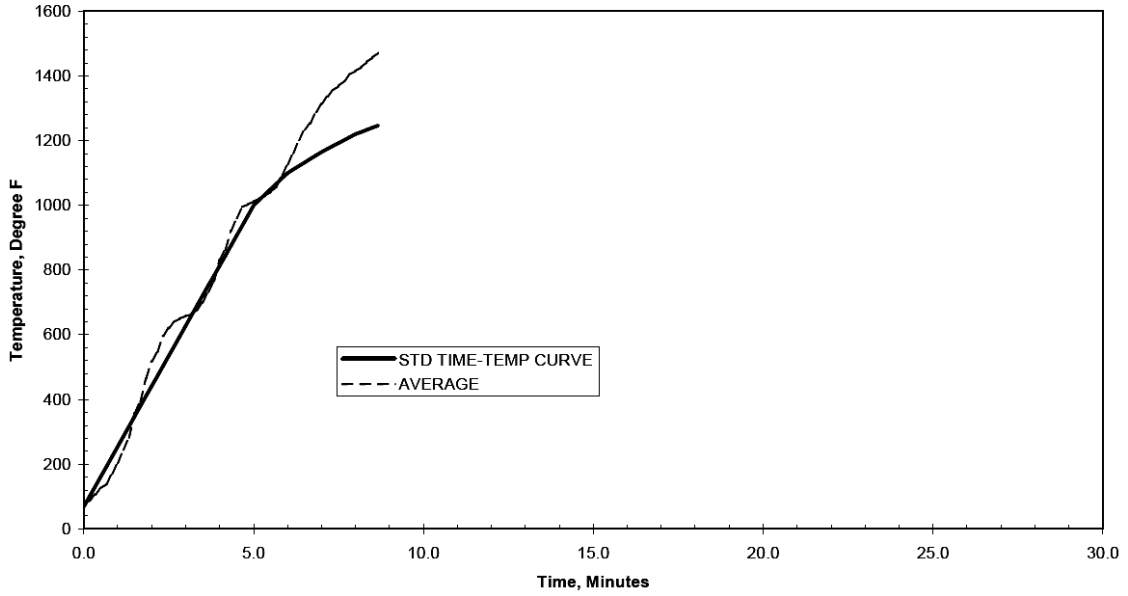

Figure 63 - UL263 Standard Time Temperature Curve and Average Furnace Temperature vs. Time for Assembly No. 5

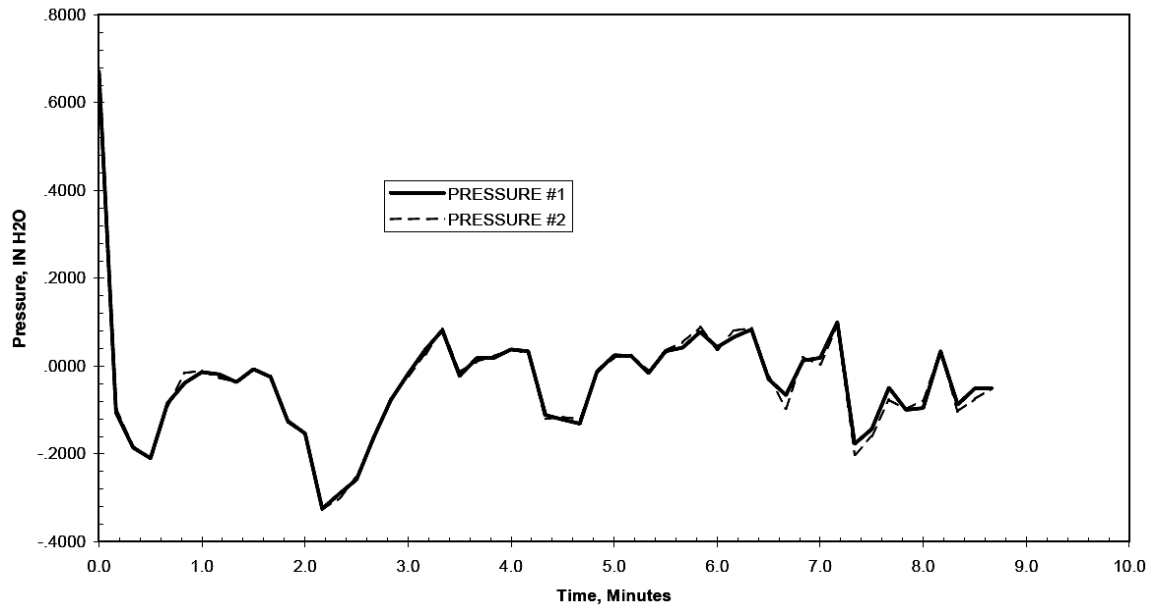
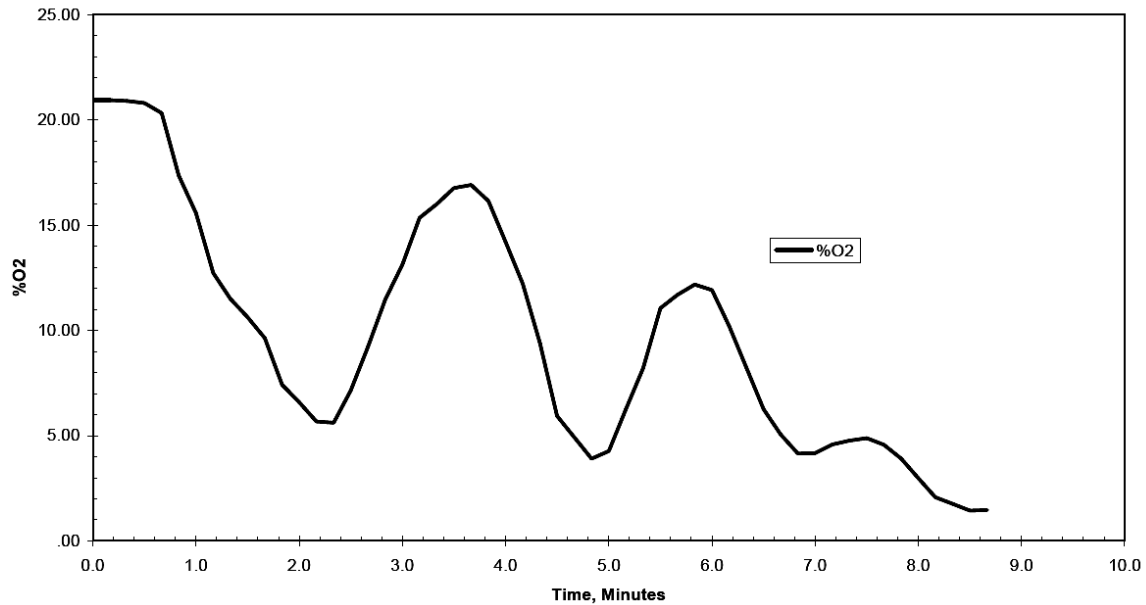
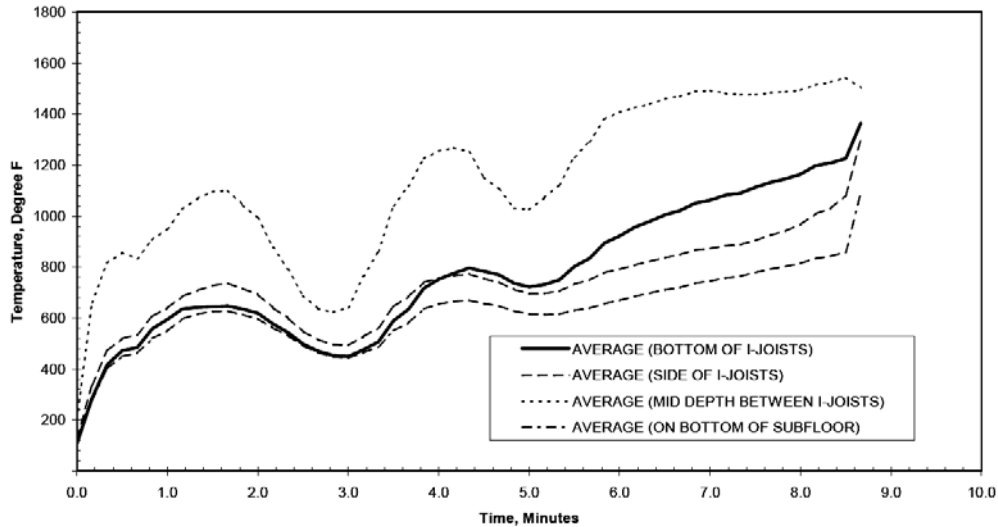

Figure 64 - Furnace Pressure vs. Time for Assembly No. 5

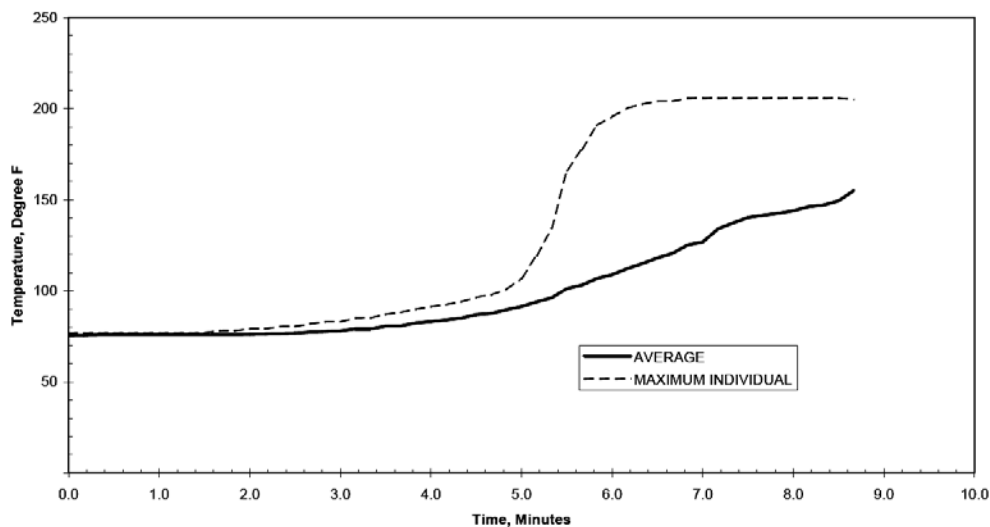

**Figure 65 - Oxygen Content vs. Time for Assembly No. 5**

A plot of the average temperatures in the joist bay areas of the floor system can be seen on Figure 66. The average and maximum temperatures of the bottom chords of the wood I Joists just before the moment of collapse (8 min 30 sec) were 1226°F and 1429°F respectively. The individual temperature was recorded by thermocouple number 25. The average and maximum temperatures of the sides of the wood I Joists just before the moment of collapse (8 min 30 sec) were 1081°F and 1475°F respectively. The individual temperature was recorded by thermocouple number 30. The average and maximum temperatures of the mid depth between the wood I Joists just before the moment of collapse (8 min 30 sec) were 1543°F and 1682°F respectively. The individual temperature was recorded by thermocouple number 41. The average and maximum temperatures of the sub floor between the wood joists just before the moment of collapse (8 min 30 sec) were 859°F and 1153°F respectively. The individual temperature was recorded by thermocouple number 49. The average and maximum temperatures of the unexposed surface just before the moment of collapse (8 min 30 sec) were 149°F and 206°F respectively. The individual temperature was recorded by thermocouple number 2. A plot of these temperatures can be seen on Figure 67.

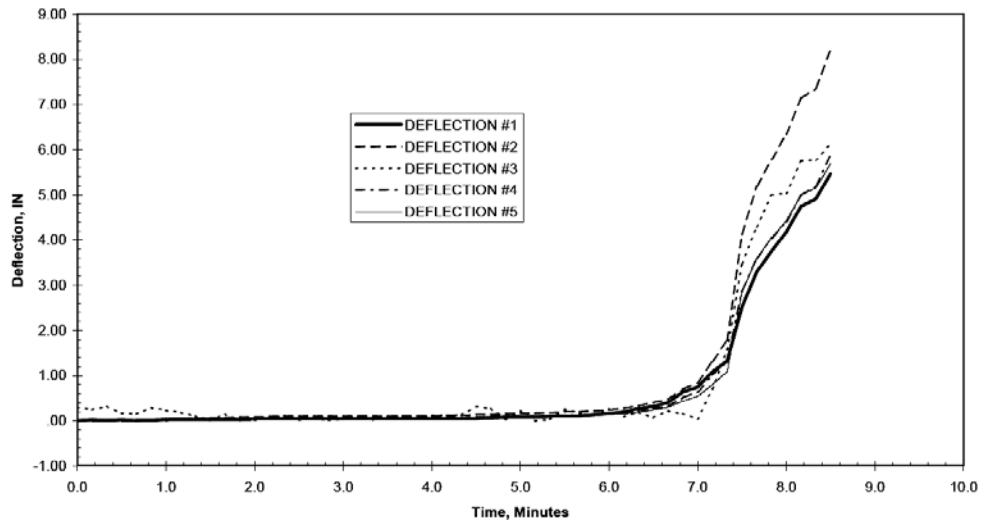

**Figure 66 - Plot of Exposed Surface Temperatures vs. Time for Assembly No. 5**



**Figure 67 - Plot of Temperatures of the Unexposed Surface vs. Time for Assembly No. 5**

The deflection of the floor-ceiling assembly during the fire experiment is shown on Figure 68. The location of each deflection transducer can be seen in Appendix A under Experiment Assembly 5. Measurable deflection began at approximately 4 minutes. A rapid deflection began at 7 minutes and continued until collapse. After the collapse of the floor system the fire was suppressed utilizing sprinklers mounted around the assembly and manual hose streams. Once the fire was suppressed, pictures were taken to document the condition of the floor system on the exposed and unexposed sides (Figure 69 through Figure 72). The failure mode for the engineered I-joists with the fire retardant coating was burn away of the web member of the joists.



**Figure 68 - Plot of Deflections vs. Time for Assembly No. 5**



**Figure 69. Unexposed side after collapse**



**Figure 70. Exposed side from North end**



Figure 71. Joist with web burn through



Figure 72. Close-up of some remaining web

## 6.6. Experiment 6

Experiment 6 examined a nominal 2 by 10 dimensional lumber floor assembly with the standard loading configuration (Figure 69 and Figure 70). The total design load for this floor system was calculated to be  $59.7 \text{ lb/ft}^2$ . The floor assembly failed at 7:00 after ignition. Observations made during the experiment of the exposed and unexposed sides of the floor assembly are detailed in Table 18.

The average furnace temperature during the experiment began below the standard time temperature curve but exceeded it at approximately 2 minutes, when the floor system ignited and the temperatures remained above the curve for the duration of the experiment (Figure 75). The furnace pressure and oxygen concentration measured in the furnace are presented in Figure 76 and Figure 77 respectively. The pressure remained between  $-0.8 \text{ in. w.c.}$  and  $0.6 \text{ in. w.c.}$  throughout the experiment. The oxygen concentration decreased to less than 5 % by 2 minutes and remained at or below that concentration until collapse.



Figure 73. Pre-test un-exposed side



Figure 74. Pre-test exposed side

Table 18 – Observations for Assembly No. 6

Exp. Time, Min:Sec	Exposed (E) or Unexposed (U) Surface	Observations
0:00	E/U	Fire test started
0:55	U	Smoke could be seen from edges of assembly and subfloor joints.
1:30	E	Smoke could be seen on bottom surface of floor.
3:00	E	Assembly not visible due to smoke and flaming.
3:30	U	Smoke and cracking were observed.
5:00	U	Smoke and cracking continued.
6:30	U	Loud popping was heard.
6:30	E	Loud popping was heard.
7:00	E/U	Fire Test Terminated due to structural failure.

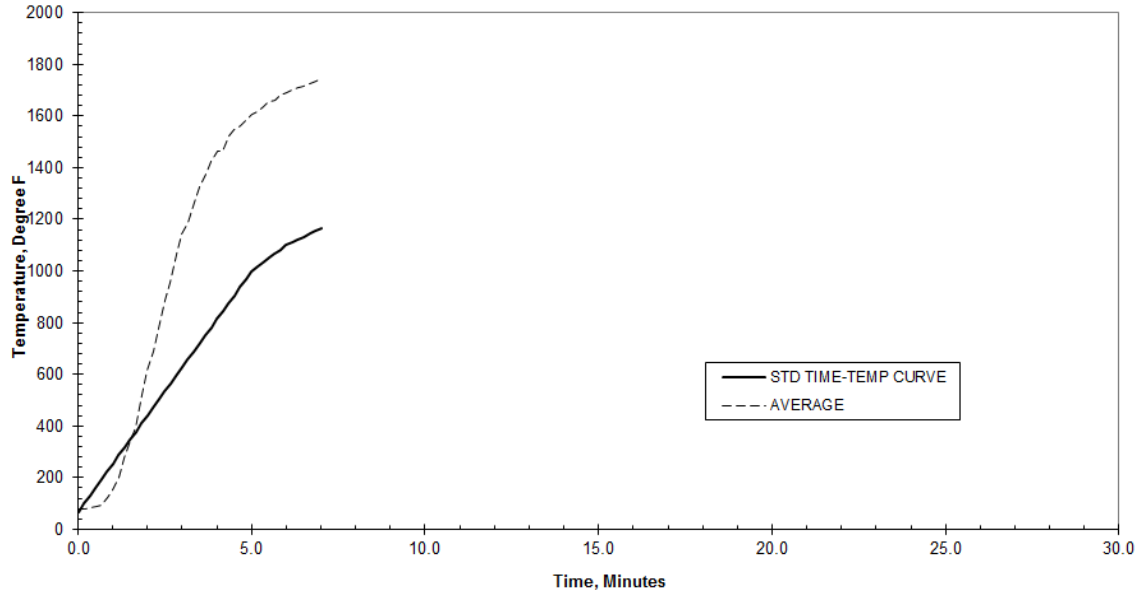

Figure 75 - UL263 Standard Time Temperature Curve and Average Furnace Temperature vs. Time for Assembly No. 6

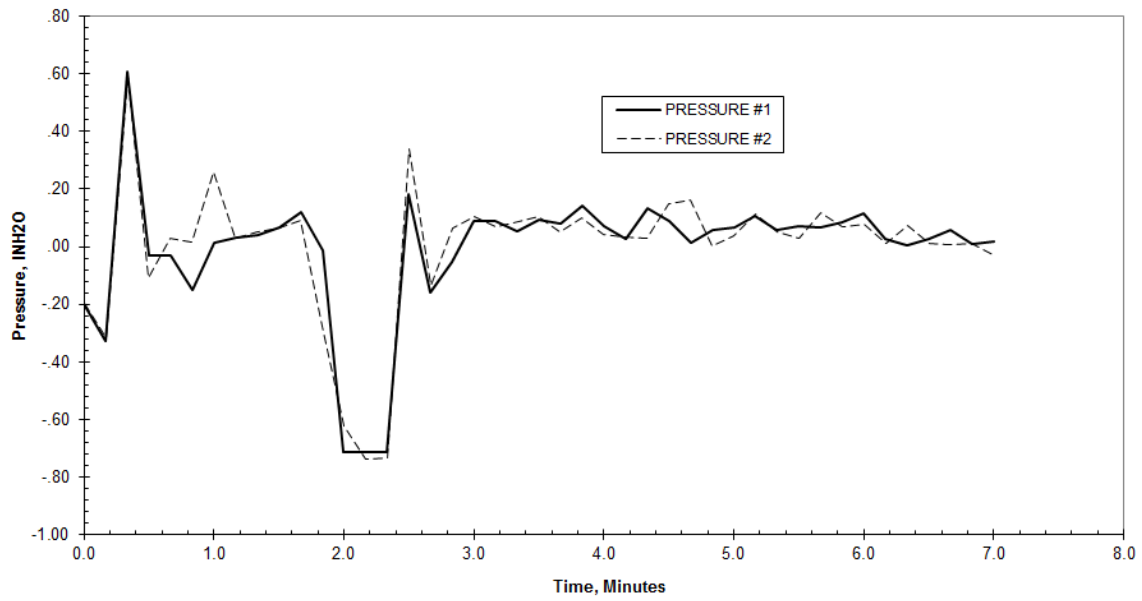
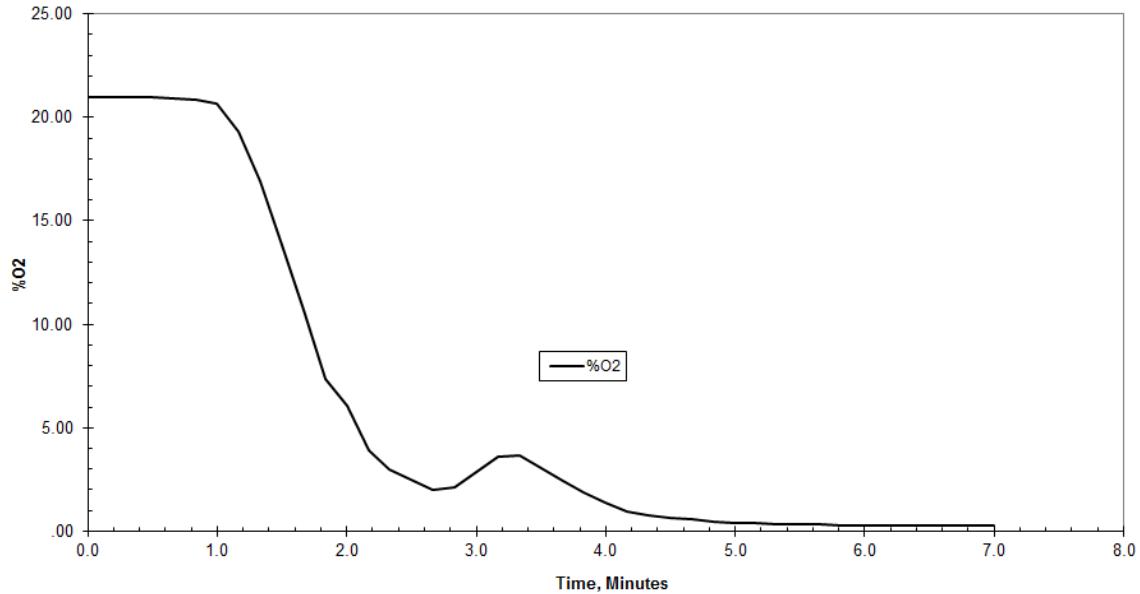

Figure 76 – Furnace Pressure vs. Time for Assembly No. 6



**Figure 77 - Oxygen Content vs. Time for Assembly No. 6**

A plot of the temperatures in the joist cavities can be seen in Figure 78. The average and maximum temperatures of the bottom chord of the joists just before the moment of collapse (7 min 0 sec) were 1639°F and 1724°F respectively. The individual temperature was recorded by thermocouple number 23. The average and maximum temperatures of the sides of the joists just before the moment of collapse (7 min 0 sec) were 1638°F and 1716°F respectively. The individual temperature was recorded by thermocouple number 32. The average and maximum temperatures of the mid depth between the joists just before the moment of collapse (7 min 00 sec) were 1653°F and 1725°F respectively. The individual temperature was recorded by thermocouple number 44. The average and maximum temperatures of the sub floor between the I Joists just before the moment of collapse (7 min 0 sec) were 1649°F and 1730°F respectively. The individual temperature was recorded by thermocouple number 52. The average and maximum temperatures of the unexposed surface just before the moment of collapse (7 min 0 sec) were 188°F and 206°F respectively. The individual temperature was recorded by thermocouple number 7. A plot of these temperatures can be seen on Figure 79.



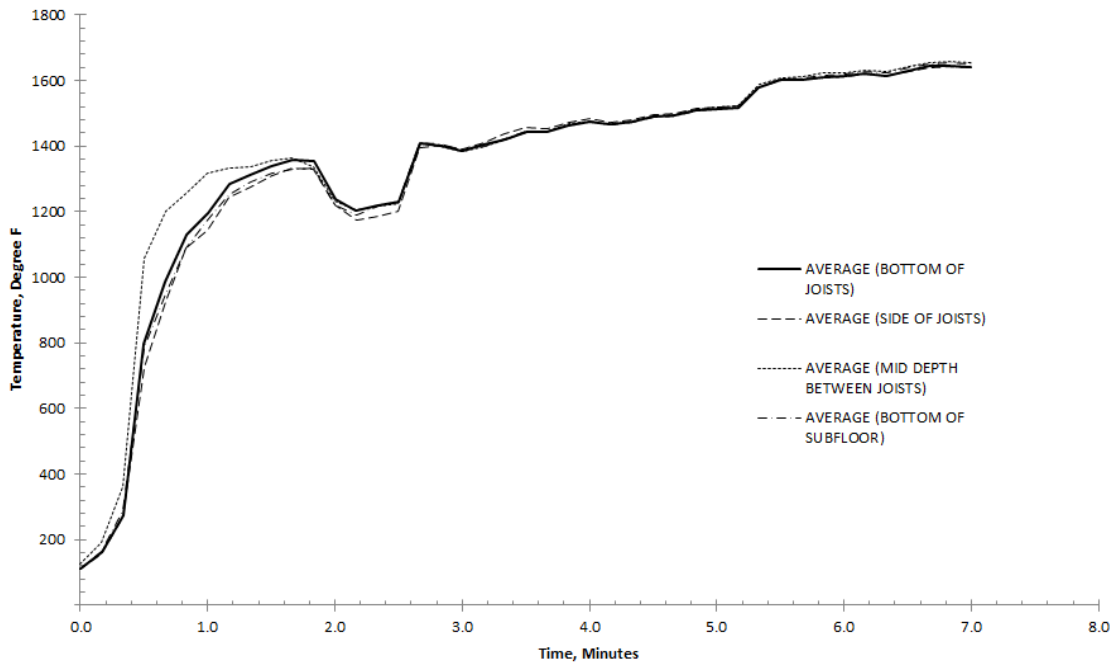

Figure 78 - Plot of Exposed Surface Temperatures vs. Time for Assembly No. 6

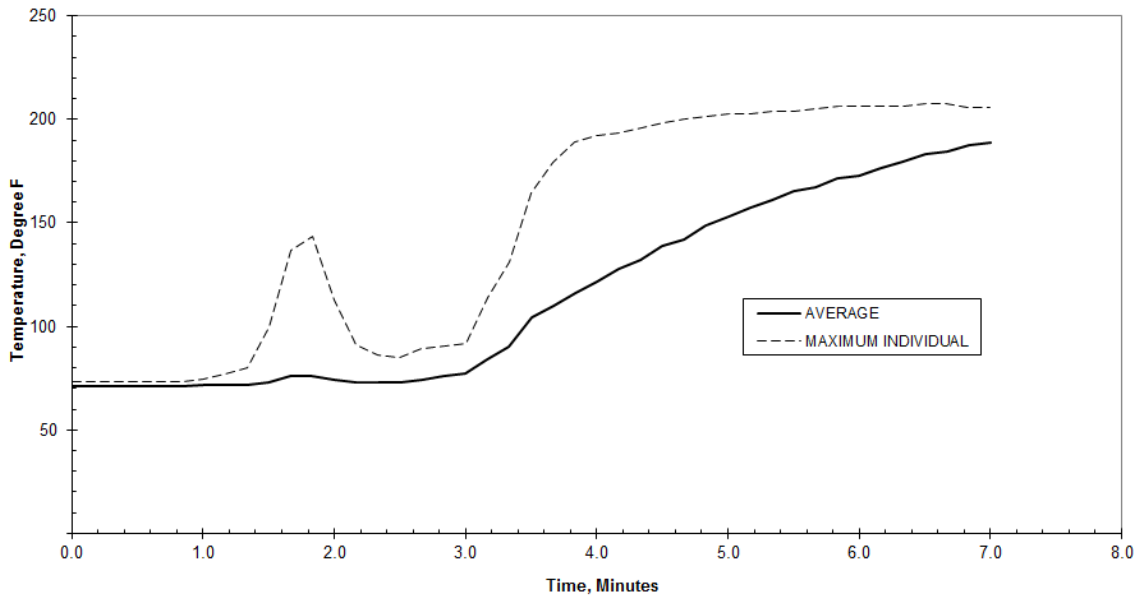
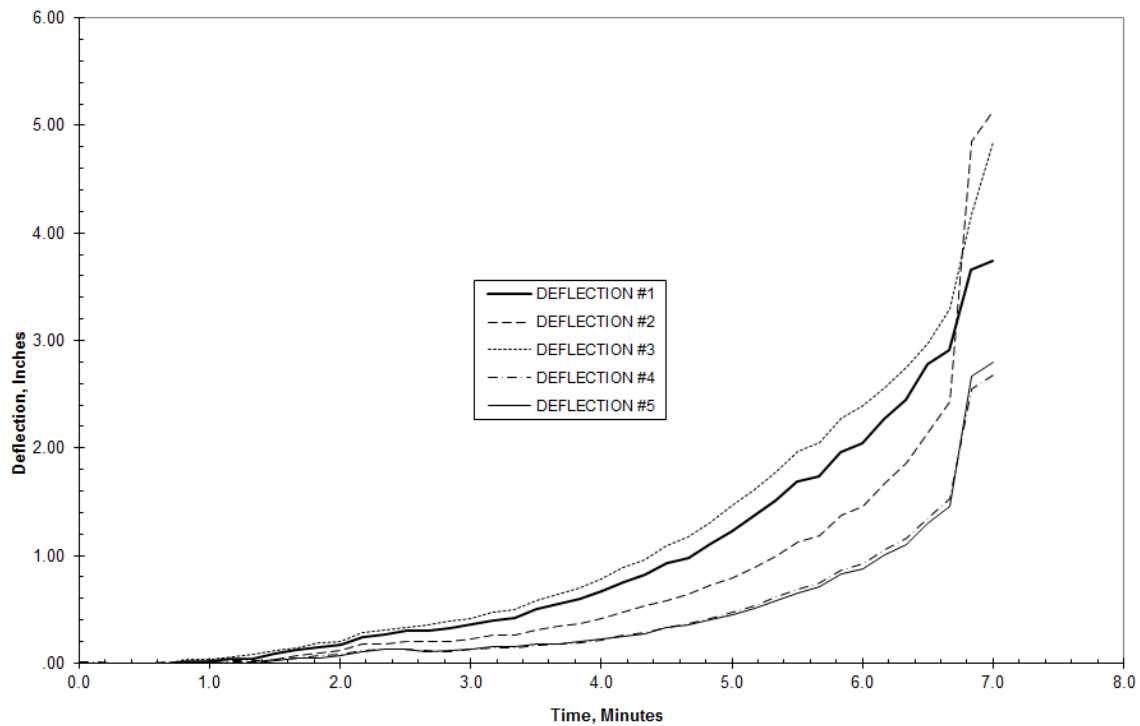

Figure 79 - Plot of Temperature of the Unexposed Surface vs. Time for Assembly No. 6

The deflection of the floor-ceiling assembly during the fire experiment is shown Figure 80. The location of each deflection transducer can be seen in Appendix A under Assembly 6. Measurable deflection began at approximately 45 seconds. Deflection steadily increased up until the time of collapse when readings ranged from 2.5 in. to 5 in. After the collapse of the floor system the fire was suppressed utilizing sprinklers mounted around the assembly and manual hose streams. Once the fire was suppressed, pictures were taken to document the condition of the floor system on the exposed and unexposed sides (Figure 81 through Figure 84). The failure mode for the traditional dimensional lumber joists was due to charring of the three fire-exposed sides of the joist which produced a reduction of the joist cross-sectional area. This area reduction, coupled with elevated temperature of the wood induced joist rupture.



**Figure 80 - Plot of Deflections vs. Time for Assembly No. 6**



**Figure 81. Unexposed side after collapse**



**Figure 82. Exposed side from North end**



**Figure 83. Joist rupture in center span**

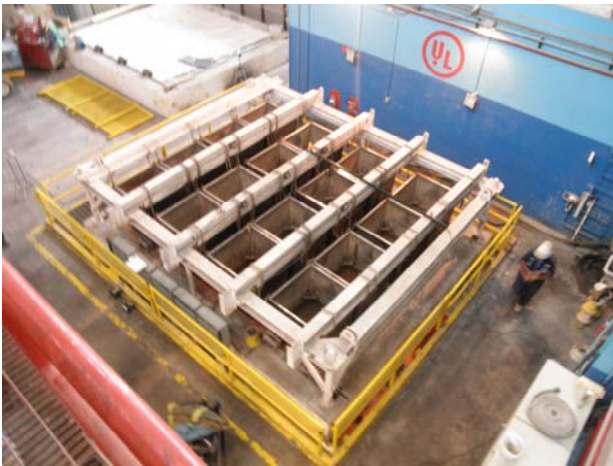

**Figure 84. Close-up of joist rupture**

## 6.7. Experiment 7

This experiment examined a nominal 2 by 8 dimensional lumber floor assembly with the standard loading configuration (Figure 85 and Figure 86). These joists were salvaged from a home that was being demolished. The home was built circa 1940 in Ohio. The total design load for this floor system was calculated to be 42.3 lb/ft<sup>2</sup>. Since the grade of the lumber was not known the calculation used the same details as the modern dimensional lumber experiment with the exception of the cross sectional area which was obviously different. The floor assembly failed at 18:05 after ignition. Observations made during the experiment of the exposed and unexposed sides of the floor assembly are detailed in

Table 19. The average furnace temperature during the experiment began below the standard time temperature curve but remained close to it for the duration of the experiment (Figure 87). The furnace pressure and oxygen concentration measured in the furnace are presented in Figure 88 and Figure 89 respectively. The pressure remained between -0.2 in. w.c. and 0.3 in. w.c. throughout the experiment. The oxygen concentration decreased to less than 2 % by 6 minutes and remained at or below that concentration until collapse.



**Figure 85. Pre-test un-exposed side**



**Figure 86. Pre-test exposed side**

**Table 19. Observations for Assembly No. 7**

<b>Exp. Time, Min:Sec</b>	<b>Exposed (E) or Unexposed (U) Surface</b>	<b>Observations</b>
1:10	U	Smoke present from subfloor joints and saddles.
2:15	U	Crackling could be heard.
4:00	E	Flaming level increase above burners.
4:15	U	Joints glowing and breathing. The laboratory cleared of smoke.
6:00	E	Flame level continues to increase. Assembly does not appear to be burning yet.
6:40	U	Smoke became present again.
8:30	E	Assembly not burning. O2 levels appear to be low.
9:00	E	Can't see assembly due to flaming.
9:00	U	Splitting noises could be heard.
9:30	U	Visible deflection could be seen at the center of the assembly
10:00	U	More frequent splitting noises could be heard.
12:00	U	Smoking and crackling continued.
13:00	U	Assembly became quiet again.
14:00	U	Assembly wavy in appearance when looking West between tanks.
15:00	U	Cracking noises could be heard again.
15:45	U	Flaming present along East edge.
16:15	E	Unexposed temperature failure prior to collapse.
16:40	U	Flaming North Center of assembly.
17:13	U	Large amount of defection could be seen.
17:30	E	No visibility into furnace.
17:50	U	Large amount of flaming.
18:05	E/U	Gas off. Structural Collapse.

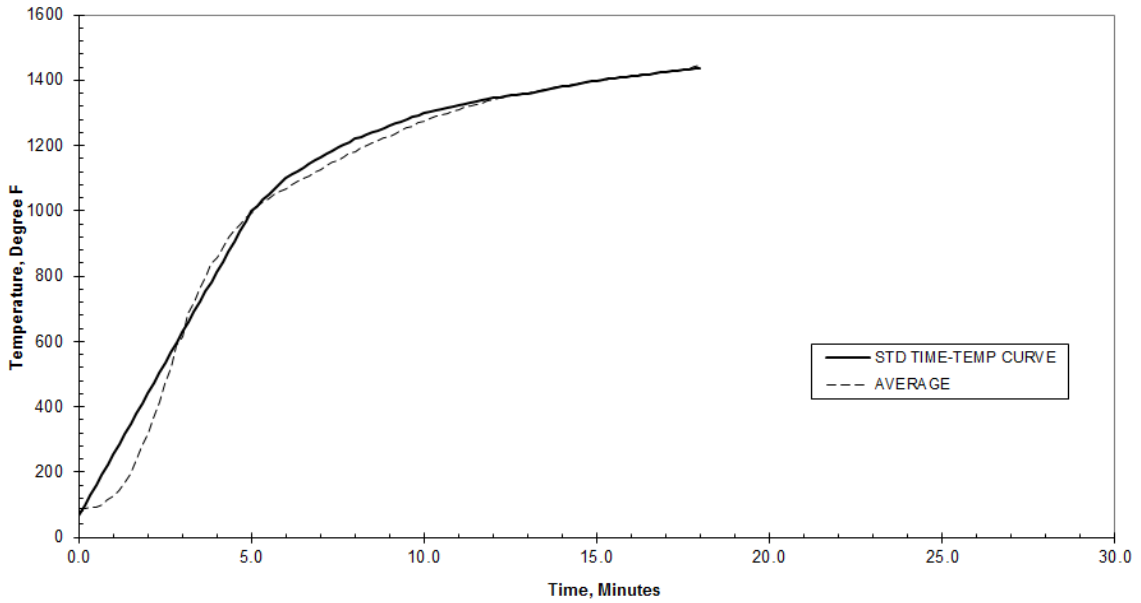

Figure 87 - UL263 Standard Time Temperature Curve and Average Furnace Temperature vs. Time for Assembly No. 7

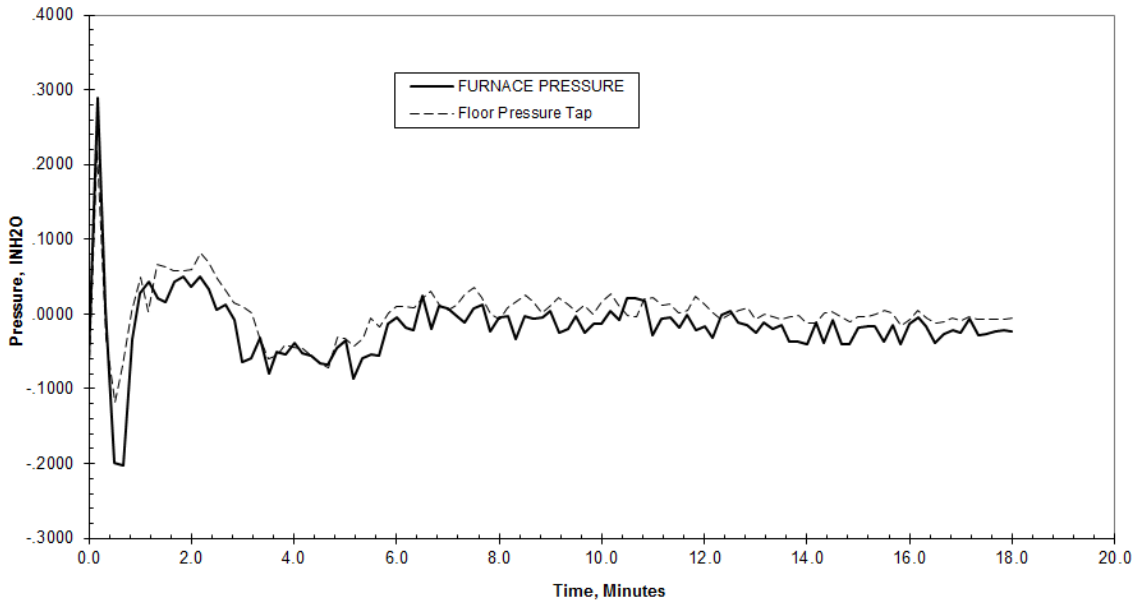
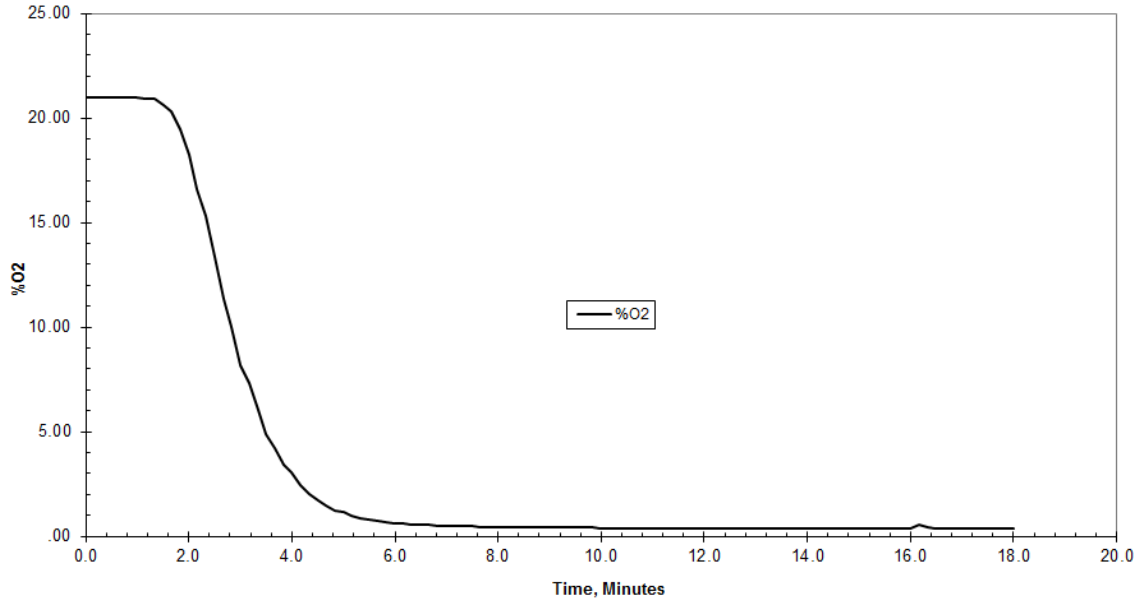

Figure 88 – Furnace Pressure vs. Time for Assembly No. 7



**Figure 89 - Oxygen Content vs. Time for Assembly No. 7**

A plot of the temperatures in proximity to the floor system can be seen in Figure 90. The average and maximum temperatures of the bottom chord of the joists just before the moment of collapse (18 min 0 sec) were 1349°F and 1443°F respectively. The individual temperature was recorded by thermocouple number 19. The average and maximum temperatures of the sides of the joists just before the moment of collapse (18 min 00 sec) were 1356°F and 1440°F respectively. The individual temperature was recorded by thermocouple number 29. The average and maximum temperatures of the mid depth between the joists just before the moment of collapse (18 min 0 sec) were 1366°F and 1438°F respectively. The individual temperature was recorded by thermocouple number 39. The average and maximum temperatures of the sub floor between the I Joists just before the moment of collapse (18 min 0 sec) were 1362°F and 1433°F respectively. The individual temperature was recorded by thermocouple number 50. The average and maximum temperatures of the unexposed surface just before the moment of collapse (18 min 0 sec) were 613°F and 1171°F respectively. The individual temperature was recorded by thermocouple number 4. A plot of these temperatures can be seen on Figure 91.



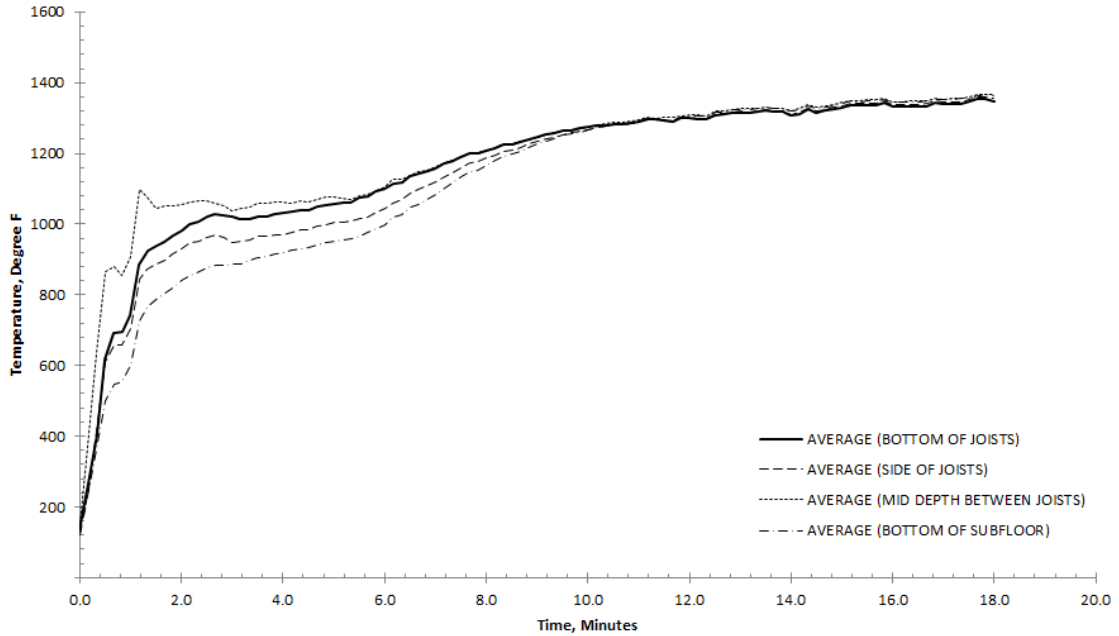

**Figure 90 - Plot of Exposed Surface Temperatures vs. Time for Assembly No. 7**

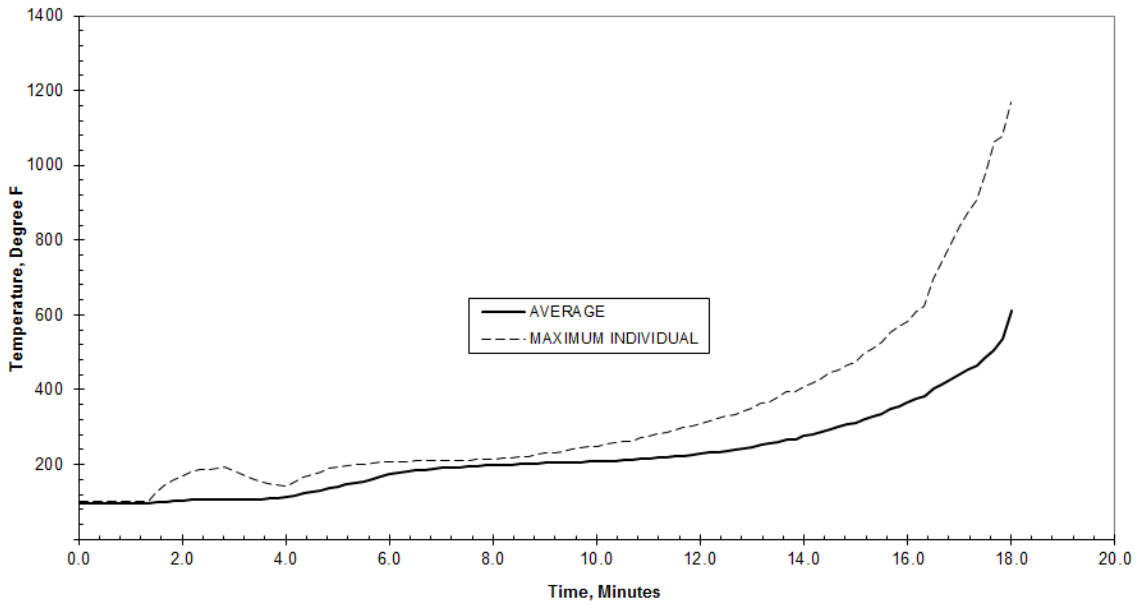

**Figure 91 - Plot of Temperature of the Unexposed Surface vs. Time for Assembly No. 7**

The deflection of the floor-ceiling assembly during the fire experiment is shown Figure 92. The location of each deflection transducer can be seen in Appendix A under Assembly 7. Measurable deflection began at approximately 2 minutes. Deflection steadily increased up until the time of collapse when readings ranged from 7.5 in. to 9 in.

After the collapse of the floor system the fire was suppressed utilizing sprinklers mounted around the assembly and manual hose streams. Once the fire was suppressed, pictures were taken to document the condition of the floor system on the exposed and unexposed sides (Figure 81 through Figure 84). The failure mode for the traditional dimensional lumber joists was due to charring of the three fire-exposed sides of the joist which produced a reduction of the joist cross-sectional area. This area reduction, coupled with elevated temperature of the wood induced joist rupture.

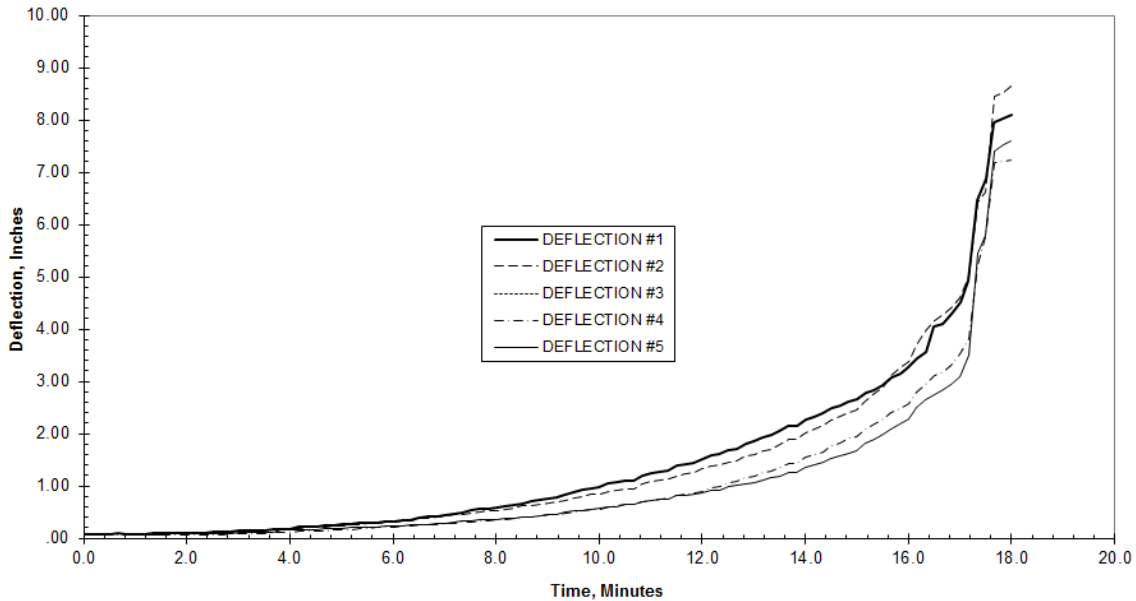

**Figure 92 - Plot of Deflections vs. Time for Assembly No. 7**



**Figure 93. Unexposed side after collapse**



**Figure 94. Exposed side from North end**



Figure 95. Joist rotation



Figure 96. Close-up of joist rupture

## 7. Discussion

The results of the ASTM E119 fire tests are expressed in terms of hours such as 1/2 hour, 1 hour or 2 hour rated assemblies. These time ratings are not intended to convey the actual time a specific structure will withstand a fire. All fires are different. Variations result from room size, combustible content and ventilation conditions. The ASTM E119 test method does provide a benchmark that enables a comparison of fire performance between test samples.

For unrestrained floor-ceiling assemblies, assemblies such as the tested samples, ASTM E119 includes the following Conditions of Acceptance:

1. The sample shall support the applied load without developing conditions that would result in flaming of cotton waste placed on the floor or roof surface.
2. Any temperature measured on the surface of the floor or roof shall not increase more than 325 °F and the average temperature measured on the surface of the floor or roof shall not increase more than 250 °F.

The results of the seven fire experiments in terms of the ASTM E119 Conditions of Acceptance are summarized in Table 20.

**Table 20 - Summary of Experimental Results ASTM E119**

Assembly	Time of 250°F avg. temperature rise on surface of floor (min:sec)	Time of 325°F max. temperature rise on surface of floor (min:sec)	Flame passage through floor (min:sec)	Time of Structural Failure (min:sec)
1. Engineered I Joists with Openings	*	*	8:10	8:10
2. Engineered Wood and Metal Hybrid Trusses	*	*	5:30	5:30
3. Engineered I Joists w/ Intumescent Coating	*	*	15:10	17:50
4. Engineered I Joists (100% Load)	*	*	2:20	2:20
5. Engineered I Joists w/ Fire Retardant Coating	*	*	8:40	8:40
6. Nominal 2 in by 10 in Dimensional Lumber (100% Load)	*	*	7:04	7:04
7. Legacy Nominal 2 in by 8 in Dimensional Lumber (100% Load)	15:40	14:20	15:45	18:05

**Notes:**

\* - This condition was not achieved during the fire experiment.

Several fire test standards similar to ASTM E119 such as ISO 834:1 Fire-resistance tests – Elements of building construction – Part 1: General requirements define load bearing capacity as the elapsed time that a test sample is able to maintain its ability to support the applied load during the fire test. The ability to support the applied load is determined when both:

(1) Deflection exceeds:  $\frac{L^2}{400d}$ ; and

(2) When the deflection exceeds  $\frac{L}{30}$ , the Rate of Deflection exceeds:  $\frac{L^2}{9000d}$

where L is the clear span measured in millimeters and d is the distance from the extreme fiber of the design compression zone to the extreme fiber of the design tensile zone of the structural element as measured in millimeters.

A summary of the ISO 834:1 load bearing capacity and the structural failure of all five assemblies can be seen on Table 21 and Figure 97.

**Table 21 - Summary of Time to Structural Failure and Failure of Load Bearing Capacity according to (ISO 834:1)**

<b>Assembly</b>	<b>Time Of Structural Failure (min:sec)</b>	<b>Failure of Load Bearing Capacity (min:sec)</b>
1. Engineered I Joists with Openings	8:10	6:10
2. Engineered Wood and Metal Hybrid Trusses	5:30	4:20
3. Engineered I Joists w/ Intumescent Coating	17:50	17:40
4. Engineered I Joists (100% Load)	2:20	2:20
5. Engineered I Joists w/ Fire Retardant Coating	8:40	7:50
6. Nominal 2 in by 10 in Dimensional Lumber (100% Load)	7:04	7:04
7. Legacy Nominal 2 in by 8 in Dimensional Lumber (100% Load)	18:05	17:40

The deflection of each assembly after application of the load is shown in Table 22.

**Table 22 - Deflection of Assembly After Application of Load**

<b>Assembly</b>	<b>Deflection (Inch)</b>
1. Engineered I Joists with Openings	0.08
2. Engineered Wood and Metal Hybrid Trusses	0.12
3. Engineered I Joists w/ Intumescent Coating	0.08
4. Engineered I Joists (100% Load)	0.23
5. Engineered I Joists w/ Fire Retardant Coating	0.08
6. Nominal 2 in by 10 in Dimensional Lumber (100% Load)	0.19
7. Legacy Nominal 2 in by 8 in Dimensional Lumber (100% Load)	0.09

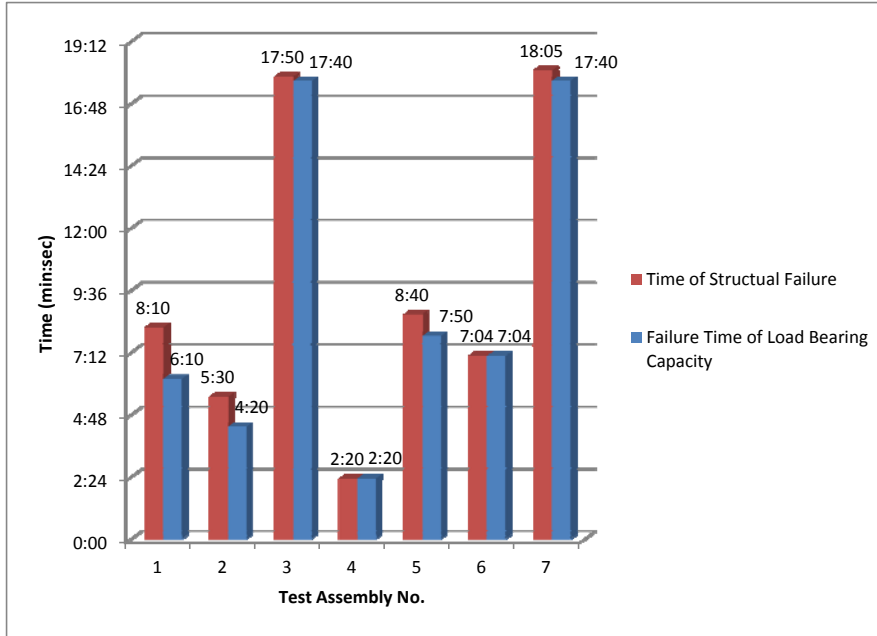
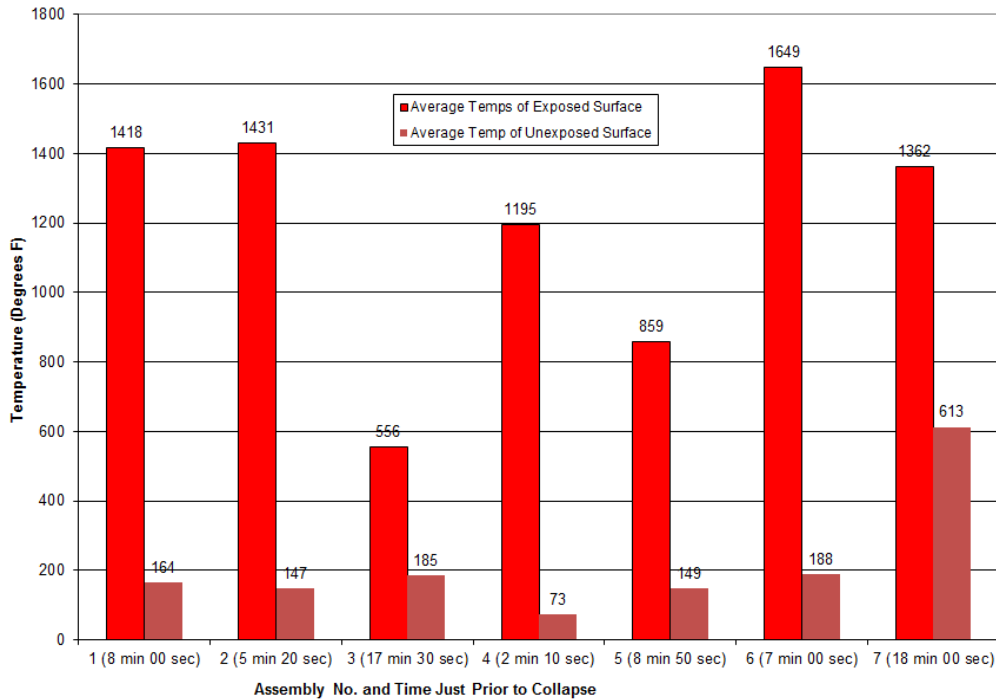

**Figure 97 - Summary of Time to Structural Failure and Failure of Load Bearing Capacity according to (ISO 834:1)**

Table 23 and Figure 98 provides a summary of the temperature data of the average temperatures on the exposed surface of each assembly and the average unexposed temperatures of each assembly just before the moment of collapse.

**Table 23 - Average temperature on unexposed and unexposed surfaces of sub-floor.**

Assembly	Average temperature of exposed side of subfloor (°F)	Average temperature of unexposed surface of floor (°F)	Time just before the moment of collapse. (min:sec)
1. Engineered I Joists with Openings	1418	164	8:00
2. Engineered Wood and Metal Hybrid Trusses	1431	147	5:20
3. Engineered I Joists w/ Intumescent Coating	556	185	17:40
4. Engineered I Joists (100% Load)	1195	73	2:10
5. Engineered I Joists w/ Fire Retardant Coating	859	149	8:30
6. Nominal 2 in by 10 in Dimensional Lumber (100% Load)	1649	188	7:00
7. Legacy Nominal 2 in by 8 in Dimensional Lumber (100% Load)	1362	613	18:00



**Figure 98 - Graph of Average Exposed and Unexposed Temperatures Just Before the Moment of Collapse**

Combining the results of the previous series of furnace experiments conducted at UL (UL, 2008) with this series of experiments provides the ability to make several comparisons. Table 24 shows all of the experiments conducted with engineered I joist floor assemblies and their times to failure. The unprotected I joist floor and the unprotected I joist/metal hybrid truss floor both collapsed in 6 minutes or less. The engineered I joist with precut openings was a larger joist measuring 16 in. tall with a slightly thicker web section so it lasted approximately 2 minutes more. Applying the fire retardant coating to the engineered I joist extended its failure time by 2 minutes and 40 seconds. Applying the intumescent coating extended the failure time by 11 minutes and 50 seconds. Applying a layer of ½ in. gypsum wallboard to the underside of the engineered I joist floor extended the failure time by 20 minutes and 43 seconds. The final experiment increased the loading to that prescribed in the standard test method, 100% of the design stress. This caused a failure time of 2 minutes and 20 seconds.

**Table 24. Engineered I joist Comparisons**

<b>Supports</b>	<b>Time to failure</b>
Engineered I Joists – Unprotected (12 in.)	6:00
Engineered Wood and Metal Hybrid Trusses - Unprotected (12 in.)	5:30
Engineered I Joists with Openings (16 in.)	8:10
Engineered I Joists w/ Fire Retardant Coating (12 in.)	8:40
Engineered I Joists w/ Intumescent Coating (12 in.)	17:50
Engineered I Joists w/ gypsum wallboard (1/2 in.)	26:45
Engineered I Joists w/ 100% Loading (12 in.)	2:20

Table 25 compares the 5 experiments conducted with dimensional lumber floor assemblies. The unprotected floor assembly collapsed at 18 minutes and 35 seconds. Applying a layer of ½ inch gypsum wallboard extended the failure time by approximately 26 minutes and the plaster and lath protection extended the failure time by approximately 60 minutes. Increasing the load to that specified in the standard decreased the failure time by 11.5 minutes, down to 7 minutes.

The final dimensional lumber experiment was conducted with a smaller cross sectional area dimensional lumber floor that was comprised of wood reclaimed from a home built circa 1940 in Ohio. Even though the cross sectional area was smaller this floor system lasted 11 minutes longer than the modern dimensional lumber experiment with the same loading condition. Figure 99 shows a side by side comparison of the new and old lumber cross sections. The modern 2 x 10 had cross sectional dimensions of 1.5 in. by 9.125 in. and a density of 32.5 lb/ft<sup>3</sup>. The old 2 x 8 had cross sectional dimensions of 1.75 in. by



7.56 in. and a density of 36.9 lb/ft<sup>3</sup>. The modern 2 x 10 had an average moisture content of 15.75 % and the old 2 x 8 had an average moisture content of 9.0 %.

**Table 25. Dimensional Lumber Comparisons**

<b>Supports</b>	<b>Time to failure</b>
Dimensional Lumber (2 x 10) - Unprotected	18:35
Dimensional Lumber (2 x 10) – Gypsum Wallboard (1/2 in)	44:40
Dimensional Lumber (2 x 10) – Plaster and Lath	79:00
Dimensional Lumber (2 x 10) w/ 100% Loading	7:00
Old Dimensional Lumber (2 x 8) w/ 100% Loading	18:05



**Figure 99. Comparison of the modern 2 x10 to the old 2 x 8.**

## 8. Tactical Considerations

Bringing together the results of these experiments or all experiments for the fire service, to understand how they may impact tactics on the fire ground is crucial to the safety of the fire service. All of the changes to the fire environment that have occurred over the past few decades make it essential for the fire service to reevaluate their tactics on a regular basis. The ability to understand the safety and stability of a floor system is very important for the fire service when it comes to conducting operations inside a structure to save lives and property.

### 8.1. Operational Timeframe

When there is a reduction in the potential collapse time of a floor system it is important for the fire service to understand where that takes place within their operational timeframe. While it is almost never known exactly how long a fire has been burning prior to the fire department being notified the fire service needs to make decisions based on how long they feel it has been burning and how safe it is to operate in a particular structure. It is possible to focus on the fire department response time as a measure of how long a fire has been burning but that does not take into account how long it was before the fire department was notified.

Every fire department has a wide range of response times within their response area depending on factors such as distance from the fire station, type of fire department and time of day just to name a few. In an analysis done by the United States Fire Administration (USFA) in 2006 they conclude, “In most of the analyses done here, response times were less than 5 minutes nearly 50% of the time and less than 8 minutes about 75% of the time. Nationally, average response times were generally less than 8 minutes. The overall 90th percentile, a level often cited in the industry, was less than 11 minutes.” (USFA, 2006)

Figure 100 details the collapse times for each of the furnace experiments and overlays the national fire service response times. Even when assuming a witnesses ignition, immediate notification of the fire service and short response time there is not much time to operate safely before floor collapse regardless of the type of floor system. This emphasizes the importance of protecting all types of flooring systems, including dimensional lumber to increase the safe operational timeframe for the fire service.

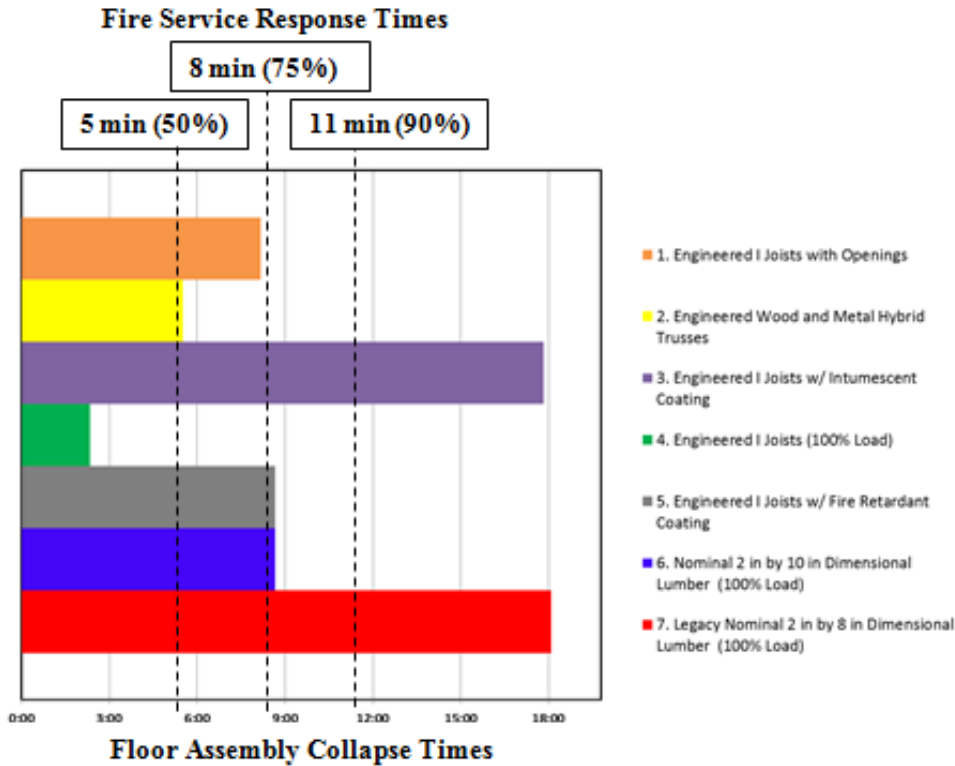

Figure 100. Fire service response times versus floor system collapse times

## 8.2. Sounding the Floor

A common fire service practice to determine the structural soundness of a floor before working on it is to sound or strike the floor with a tool such as a haligan bar or an ax to see if sponginess or softness can be felt. In every experiment except for one, the old dimensional lumber, the OSB floor decking remained in place and did not burn through. When burn through did occur it was over 17 minutes into the experiment. All of the other unprotected floor systems failed well before this time and therefore striking the floor would result in hitting solid OSB floor decking although the joists below the floor may be compromised. This would be masked even further if there was a finish floor such as carpet, hardwood or tile on top of the sub flooring. Striking the floor should not be used as a reliable indicator that the floor is safe to operate on top of.

## 8.3. Thermal Imaging Cameras

It was highlighted in the previous 2008 UL study and 2010 NIST study that thermal imaging cameras should not be used to determine structural integrity of a floor system. The data from this series of experiments supports both of those studies. Table 26 shows the temperatures on the exposed and unexposed sides of the floor system moments prior to collapse. The only exception was the legacy lumber floor (Experiment 7) because it

had burned through prior to collapse resulting in high exposed side temperatures. These temperatures are on the subfloor and would be further masked by the finish floor like carpet or hardwood. Thermal imaging cameras can be a great tool for determining if there is a basement fire but should not be used to determine structural integrity of a floor system. There were no signs seen by the thermal imaging camera during these experiments that could be considered a predictive indicator of pending collapse.

**Table 26. Comparison of floor temperatures above and below**

<b>Assembly</b>	<b>Average temperature of exposed side of subfloor (°F)</b>	<b>Average temperature of unexposed surface of floor (°F)</b>
1. Engineered I Joists with Openings	1418	164
2. Engineered Wood and Metal Hybrid Trusses	1431	147
3. Engineered I Joists w/ Intumescent Coating	556	185
4. Engineered I Joists (100% Load)	1195	73
5. Engineered I Joists w/ Fire Retardant Coating	859	149
6. Nominal 2 in by 10 in Dimensional Lumber (100% Load)	1649	188
7. Legacy Nominal 2 in by 8 in Dimensional Lumber (100% Load)	1362	613

## 9. Code Implications

Based on some previous research by UL and others as well as concerns from the fire service a code change was developed by an ad hoc group consisting of fire service and building industry representatives. The following is the code language that has been adopted for inclusion in the 2012 edition of the International Residential Code.

*R501.3 Fire protection of floors. Floor assemblies, not required elsewhere in this code to be fire resistance rated, shall be provided with a ½ inch gypsum wallboard membrane, 5/8 inch wood structural panel membrane, or equivalent on the underside of the floor framing member.*

*Exceptions:*

1. *Floor assemblies located directly over a space protected by an automatic sprinkler system in accordance with Section P2904, NFPA 13D, or other approved equivalent sprinkler system.*
2. *Floor assemblies located directly over a crawl space not intended for storage or fuel-fired appliances.*
3. *Portions of floor assemblies can be unprotected when complying with the following:*
  - 3.1 *The aggregate area of the unprotected portions shall not exceed 80 square feet per story.*
  - 3.2 *Fire blocking in accordance with Section R302.11.1 shall be installed along the perimeter of the unprotected portion to separate the unprotected portion from the remainder of the floor assembly.*

4. *Wood floor assemblies using dimension lumber or structural composite lumber equal to or greater than 2-inch by 10-inch nominal dimension, or other approved floor assemblies demonstrating equivalent fire performance.*

Much like other new code language there are some areas that are left up to interpretation as a result of several compromises. Some of the experiments conducted attempted to try to support this language and future iterations of the code.

This study can begin to address Exception 4 of the proposed change. First it allows 2-inch by 10-inch nominal dimensional lumber to be unprotected. This sets the benchmark for other floor assemblies. Two experiments help to define this benchmark. The dimensional lumber experiment with a modified load failed at 18:43 and the dimensional lumber floor with 100% of the design load failed at 7:00.

It can be argued that this is not an acceptable benchmark for level of performance because 18:43 can be justified as being within the fire services operation timeframe as described in the previous section, which provides little to no factor of safety. The final experiment with old dimensional lumber raises the question as to whether all dimensional lumber can be adequately described by its nominal dimensions. The older reclaimed dimensional lumber didn't reach failure until 160% longer than the modern dimensional lumber. While the fire service suggests that the factor of safety provided by older dimensional lumber was acceptable the experimental results show that new dimensional lumber is significantly different in terms of performance under fire conditions. Protecting the dimensional lumber as well in future code requirements would eliminate this fire performance change in dimensional lumber and provide a more reasonable factor of safety for the fire service.

Another code implication is the definition of "equivalent" as used in the following section, "*Floor assemblies, not required elsewhere in this code to be fire resistance rated, shall be provided with a ½ inch gypsum wallboard membrane, 5/8 inch wood structural panel membrane, or equivalent on the underside of the floor framing member.*" Two different products, utilizing two different technologies, were tested to see if they provide equivalent protection to an engineered floor system with ½ in. gypsum wallboard. The benchmark for this equivalency is interpreted to be approximately 26:45 which is the approximate performance of the three engineered floor systems experimented with ½ in. gypsum board protection (Table 27).

The first technology tested for equivalence was a spray applied fire retardant coating. This product is designed to be applied on wood to improve the flame spread properties of the wood product. This technology only provided minimal impact to extending the time to structural collapse, and it did not come close to providing "equivalent" protection to gypsum wallboard (Table 27).

The second technology tested for equivalence was a spray applied intumescent coating which was UL Classified for Fire Resistance for multiple applications when applied to

steel sections. This product is currently not designed for use on wood. While this technology extended the collapse time by almost 200% it did not reach the protection level of gypsum wallboard. Currently, this product is cost prohibitive when compared to the cost of gypsum wallboard and its compatibility with wood is unknown but thought to be degrading over time due to its chemical composition.

**Table 27. Collapse times of engineered floor systems with protection technologies**

<b>Assembly</b>	<b>Protection</b>	<b>Collapse Time</b>
Engineered I joist (12 inch deep)	1/2 inch regular gypsum wallboard	26:45
Parallel chord truss with steel gusset plate connections (14 inch deep)	1/2 inch regular gypsum wallboard	29:15
Parallel chord truss with glued connections (14 inch deep)	1/2 inch regular gypsum wallboard	26:45
Engineered I joist (12 inch deep)	Spray applied fire retardant coating	8:40
Engineered I joist (12 inch deep)	Spray applied intumescent coating	17:50

## 10. Future Research

Additional research should be conducted to further understand how dimensional lumber has changed over time in regards to structural stability. Newer lumber growth methods impact on fire performance should be further investigated. In addition, the efficacy of 5/8 inch wood structural panel membrane should be determined and compared to the performance of various modern structural members as documented in this report.

## 11. Summary

Seven fire experiments were conducted on representative floor construction to develop comparable fire performance data. All assemblies were intended to represent typical residential construction and included dimensional lumber, engineered wood I-joists and trusses. The assemblies did not include a ceiling and were considered unprotected floor assemblies representative of a basement with no ceiling membrane. Two of the assemblies were coated with a topical treatment to assess its ability to provide additional structural integrity.

Collapse times ranged from 2:20 to 18:05. Three fire service tactical considerations were identified and several code implications were discussed. The results of these experiments were combined with a series of experiments conducted by UL in 2008, which took place on the same floor furnace. It was highlighted that the collapse of all unprotected floor

systems, including dimensional lumber, happens well within the potential operational timeframe of the fire service. Two additional considerations discuss procedures used to determine the structural integrity of the floor are not necessarily reliable, sounding of the floor, deflection and the use of thermal imaging cameras.

Code implications discussed include the inability of spray applied fire retardants or intumescent to provide “equivalent” protection to that of a ½ inch layer of gypsum board. Additionally that dimensional lumber and its structural stability may have changed over time. Older nominal 2 x 8’s did not collapse until after 18 minutes while the newer nominal 2 x 10 collapsed at 7 minutes.

## 12. References

- Factory Mutual Research . (1974). *ASTM E-119 Fire Endurance Test of a Floor Assembly (Design FC 212)*. Norwood: Factory Mutual Research.
- Factory Mutual Research . (1974). *ASTM E-119-73 Fire Endurance Test* . Norwood: Factory Mutual Research .
- Factory Mutual Research . (1977). *A Floor-Ceiling Assembly Consisting of Wood Trusses with a Plywood Floor*. Norwood: Factory Mutual Research .
- Factory Mutual Research. (1974). *ASTM E119 Fire Endurance Test of a Floor Assembly (Design FC 209)*. Norwood: Factory Mutual Research.
- Factory Mutual Research. (1974). *ASTM E119 Fire Endurance Test of a Floor Assembly (Design FC-211)*. Norwood: Factory Mutual Research.
- Fahy, D. R. (2010). *U.S. Fire Service* . National Fire Protection Association Fire Analysis and Research Division.
- Grundahl, K. (1992). *National Engineered Light Weight Construction Fire Research Technical Report*. National Fire Protection Research Foundation.
- Madrzykowski, D. (2011). *NIST Technical Note 1709 - Examination of the Thermal Conditions of a Wood Floor Assembly above a Compartment Fire*. Gaithersburg: National Institute of Standards and Technology.
- White, R.H. (1983). *Replicate Fire Endurance Tests of an Unprotected Wood Joist Floor Assembly*. Madison: Forest Products Laboratory.
- Son, B. (1973). *Fire Endurance Tests of Unprotected Wood-Floor Constructions for Single Family Residences*. Washington D.C. : National Bureau of Standards Reports.
- Son, B. (1973). *Fire Endurance Test of a Steel Sandwich Panel Floor Construction, NBSIR 73-164*. National Bureau of Standards.
- Son, B. (1973). *Fire Endurance Tests of Unprotected Wood-Floor Constructions for Single Family Residences: NBSIR 73-263*. Washington D.C.: National Bureau of Standards Reports.
- Son, B. (1973). *Fire Endurance of Plywood on Steel Joist Floor Assemblies, With and Without Ceiling, NBSIR 73-14-1*. National Bureau of Standards.

Subcommittee on Fire Resistance Classifications of the Central Housing Committee on Research, D. a. (1942). *BMS 92 Fire Research Classification of Building Constructions*. United States Department of Commerce and the National Bureau of Standards.

Underwriters Laboratories, Inc. (2008). *Report on Structural Stability of Engineered Lumber in Fire conditions*. Northbrook: Underwriters Laboratories.

Underwriters Laboratories, Inc. (2009). *Structural Stability of Engineered Lumber in Fire Conditions*. Northbrook: Underwriters Laboratories, Inc. .

USFA. (2006). *Structure Fire Response Times*. Emmittsburg: USFA National Fire Data Center.

### **13. Acknowledgements**

UL would like to thank the National Institute of Standards and Technology for funding this research through the American Reinvestment and Recovery Act Grant program.



## Appendix A

Appendix A includes the construction details for each assembly, plan and section views showing details, instrumentation layouts and loading details.

Assembly No. 1:

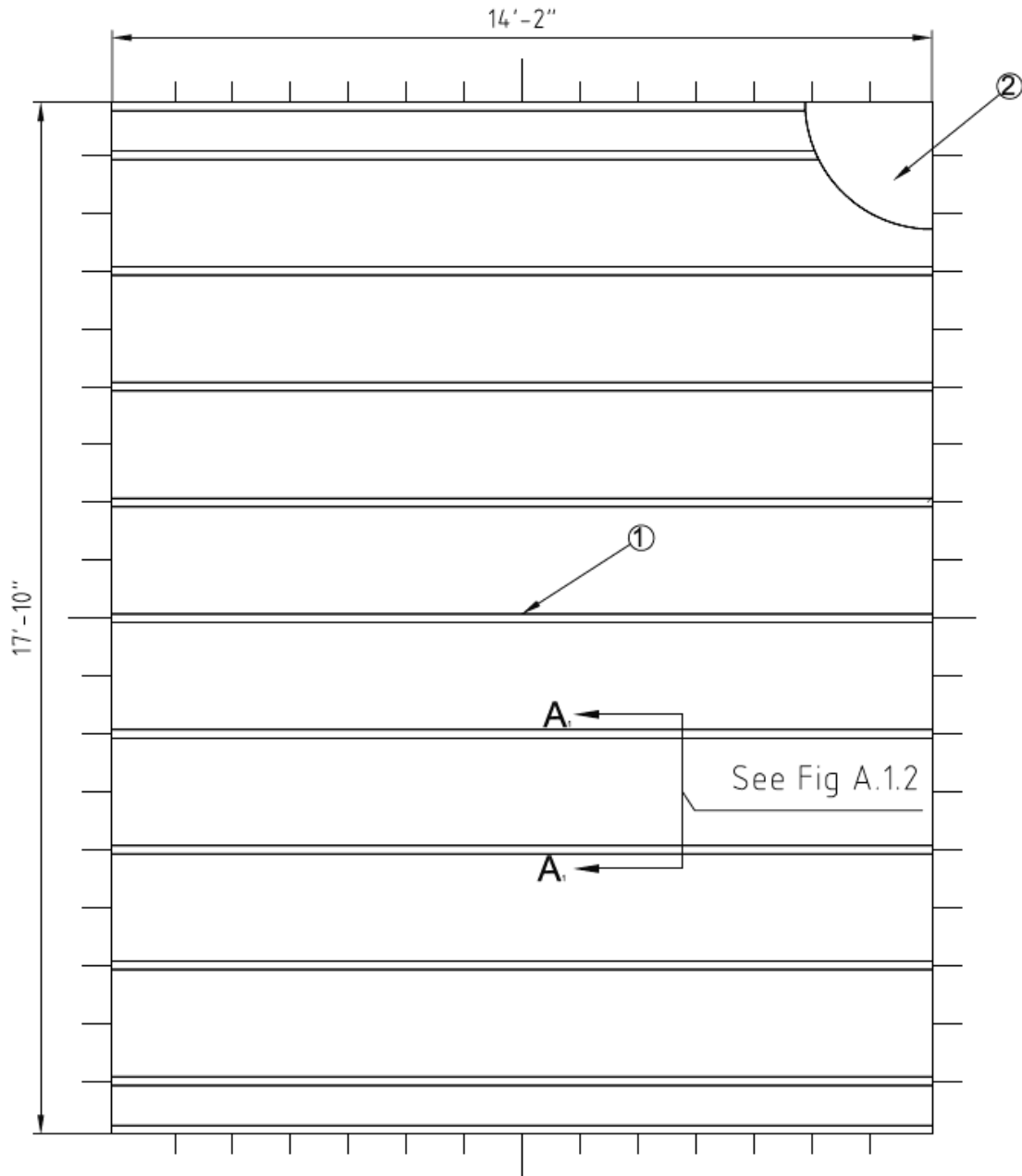
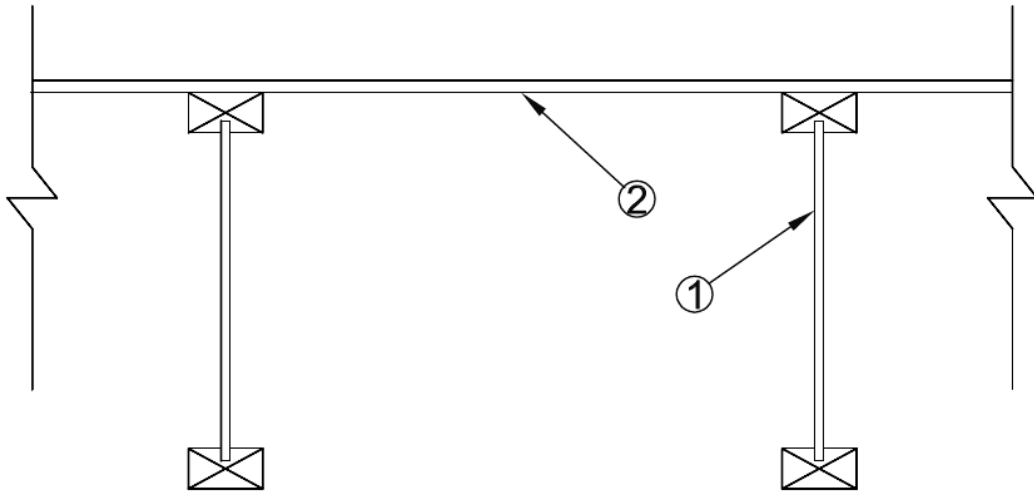

Figure A.1.1 – Construction Layout

Assembly No. 1



## SECTION A<sub>1</sub>-A<sub>1</sub>

- 1) 16 in. Engineered I Joists with Openings Spaced 24 in. O.C.
- 2) OSB  $\frac{23}{32}$  in. APA rated sheathing.

Figure A.1.2 – Construction Layout Section A<sub>1</sub>-A<sub>1</sub>.

Assembly No. 1

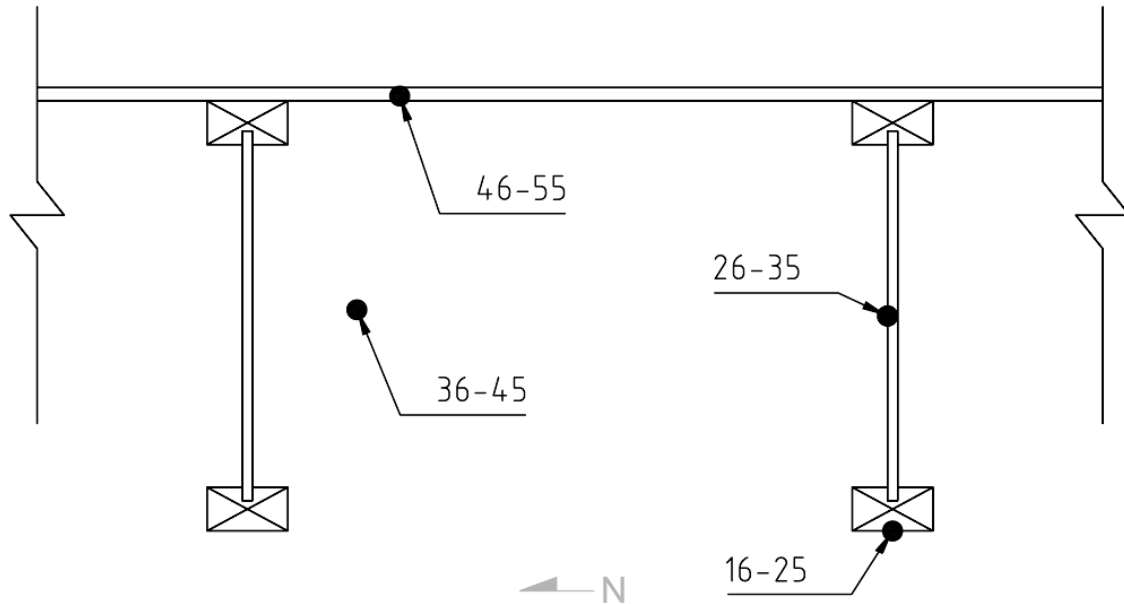

## Elevation - Thermocouple Location

Engineered I Joists with Openings, Plenum,  
Bottom of Sub Floor

TC # LOCATION

16-25 On Bottom of I Joists

26-35 On Side of I Joists at Mid Depth, Facing North

36-45 Mid Depth Between I Joists

46-55 On Bottom of Subfloor

Figure A.1.3 – Thermocouple Locations - Elevation.

Assembly No. 1

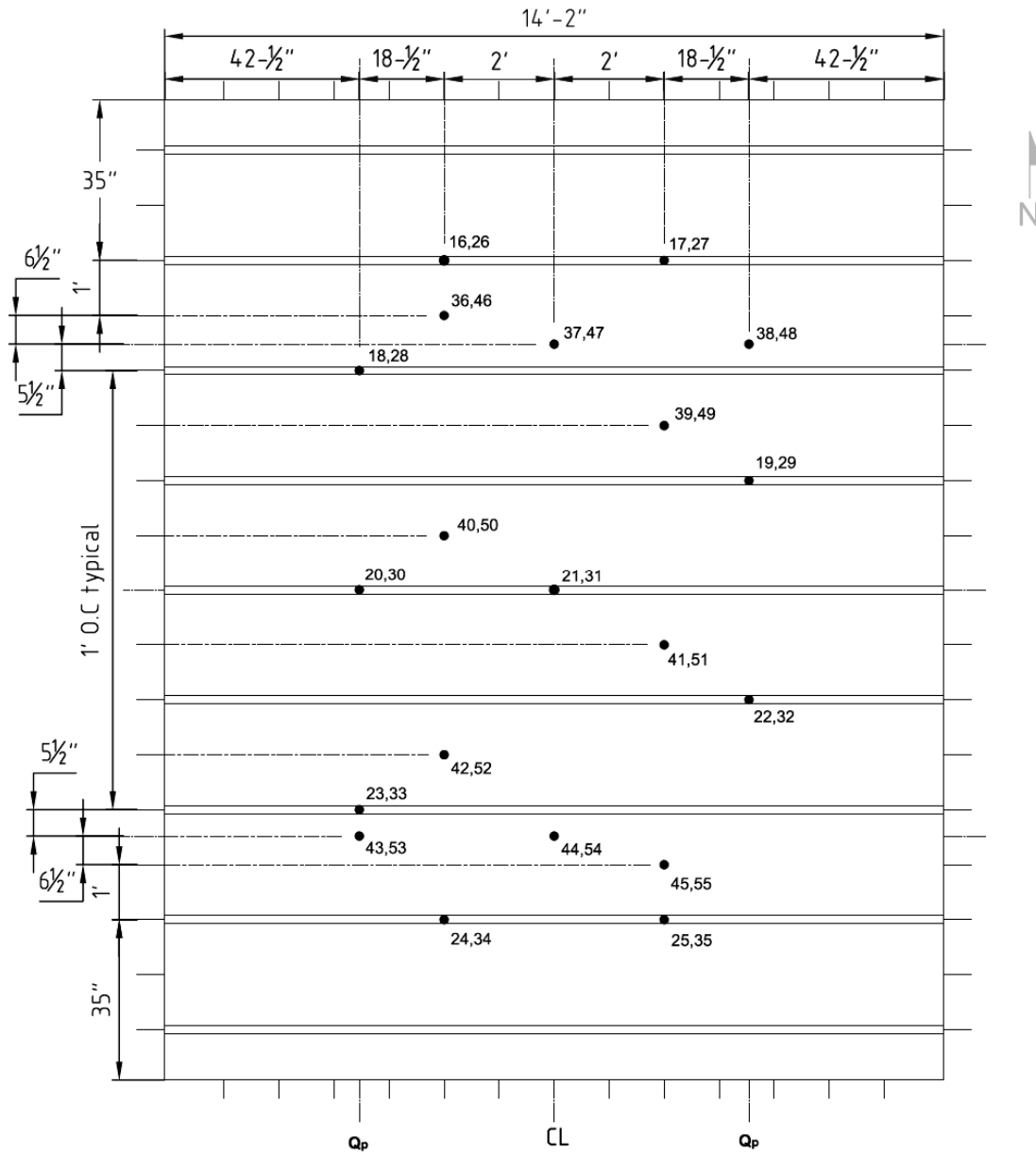

Assembly No. 1

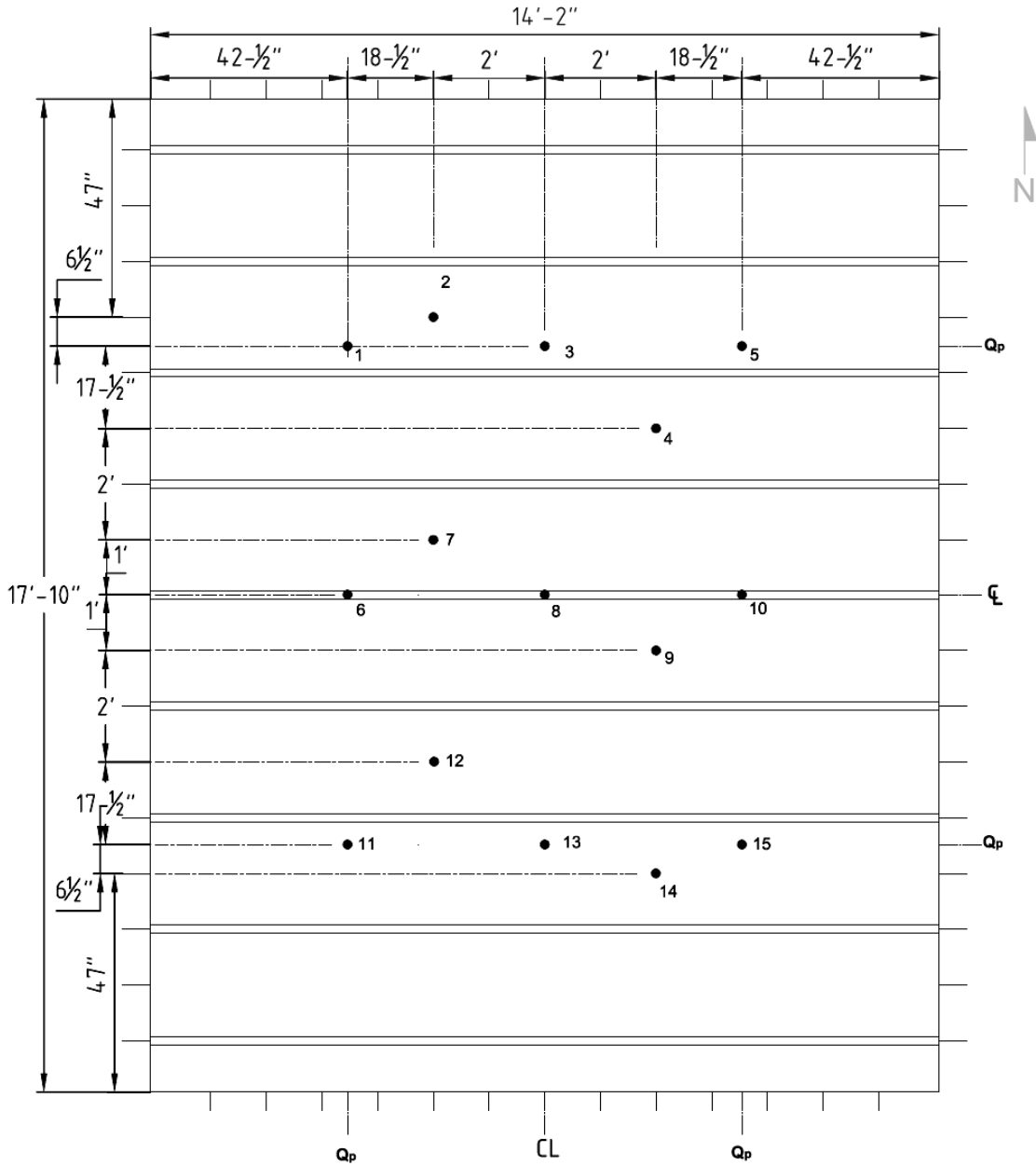

Figure A.1.5 – Thermocouple Locations on Unexposed Surface.

Assembly No. 1

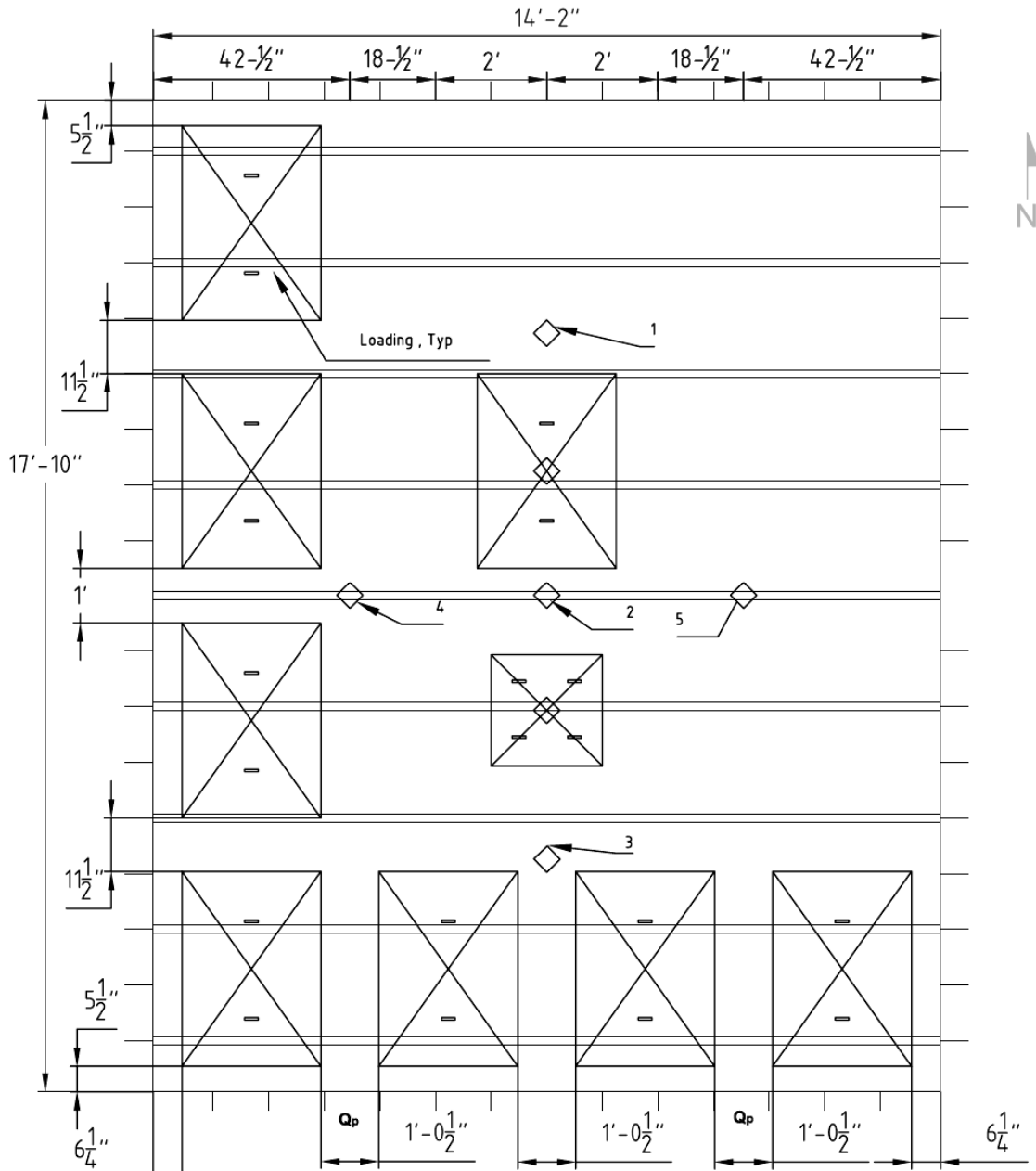

Figure A.1.6 – Loading and Instrumentation Layout (See Figure A.1.7).

**Assembly No. 1**

**Deflection Transducers:**



- 1 - Along E-W Centerline, North Quarter-point.
- 2 - Along E-W Centerline, Center-point.
- 3 - Along E-W Centerline, South Quarter-point.
- 4 - Along N-S Centerline, East Quarter-point.
- 5 - Along N-S Centerline, West Quarter-point.

**Audio Recordings: (Not Shown)**

- 1 - Mannequin No. 1 (Hands & Knees)

**Video Camera Recordings: (Not Shown)**

- Channel 1409 - floor level view from southeast corner
- Channel 1411 - IR camera from curing cell roof east center
- Channel 1412 - furnace camera from northwest corner
- Channel 1416 - overhead from east center of assembly

- Channel 1413 - overhead from south center of assembly
- Channel 1503 - overhead from west center of assembly

**Furnace Pressure Probes: (Not Shown)**

- 1 - located near northeast corner
- 2 - located near southwest corner

**Oxygen Content : (Not Shown)**

located in E exhaust duct.

**Figure A.1.7 – Loading and Instrumentation Key**

Assembly No. 2

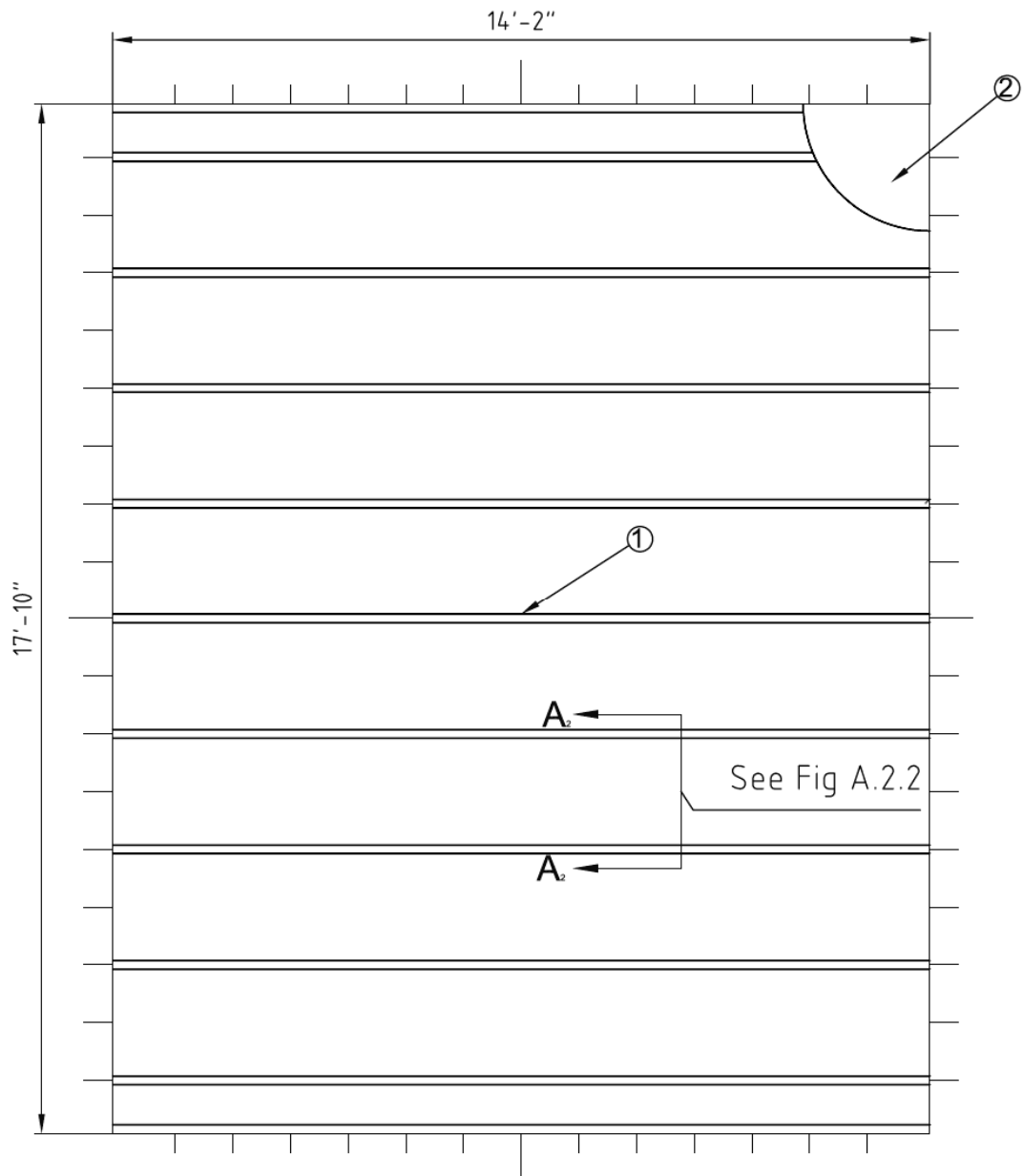
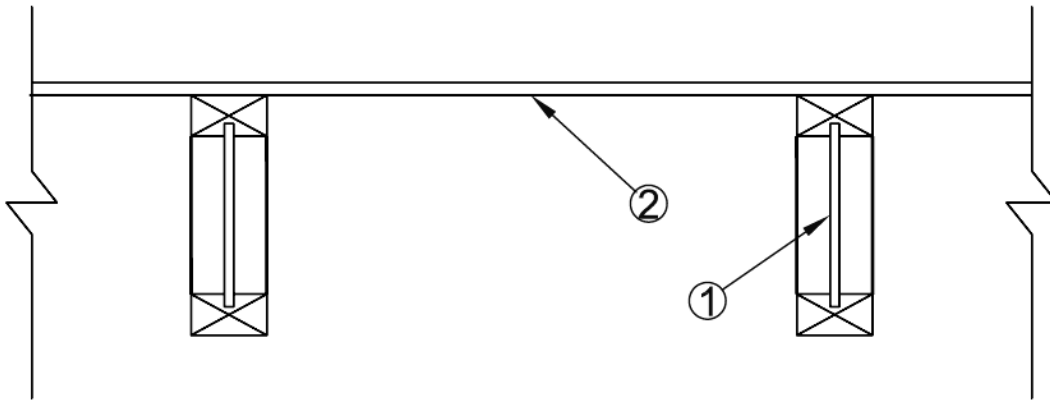

Figure A.2.1 – Construction Layout



Assembly No. 2



## SECTION A<sub>2</sub>-A<sub>2</sub>

- 1) 14 in. Deep Trusses with Wooden Top and Bottom Chords and Metal Webs Spaced 24 in. O.C.
- 2) OSB  $\frac{23}{32}$  in. APA rated sheathing.

Figure A.2.2 – Construction Layout Section A<sub>2</sub>-A<sub>2</sub>.

Assembly No. 2

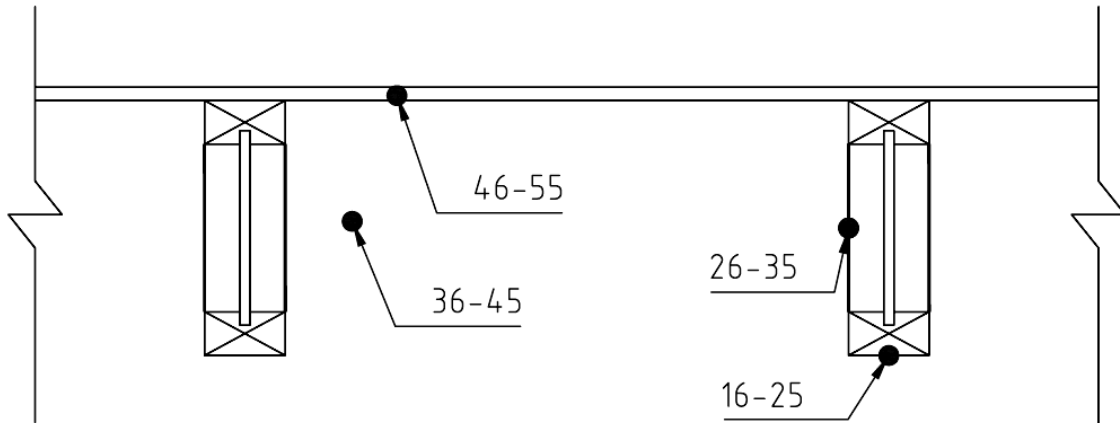

## Elevation - Thermocouple Location

Engineered Trusses, Plenum, Bottom of Sub Floor

### TC # LOCATION

16-25 On Bottom of Engineered Truss

26-35 On Side of Engineered Truss at Mid Depth, Facing North

36-45 Mid Depth

46-55 On Bottom of Subfloor

**Figure A.2.3 – Thermocouple Locations - Elevation.**

Assembly No. 2

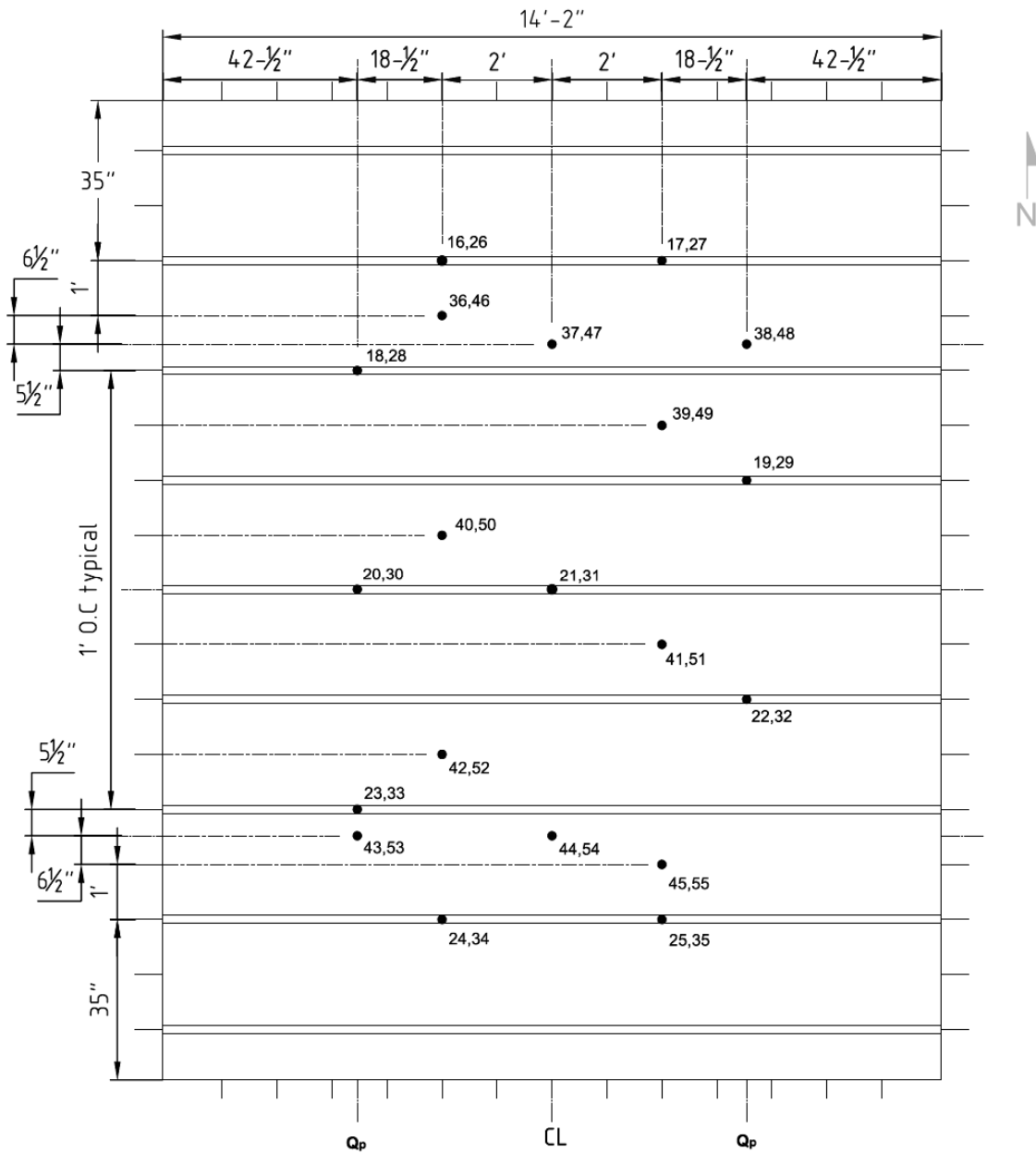

Figure A.2.4 – Thermocouple Locations on Exposed Surface.

Assembly No. 2

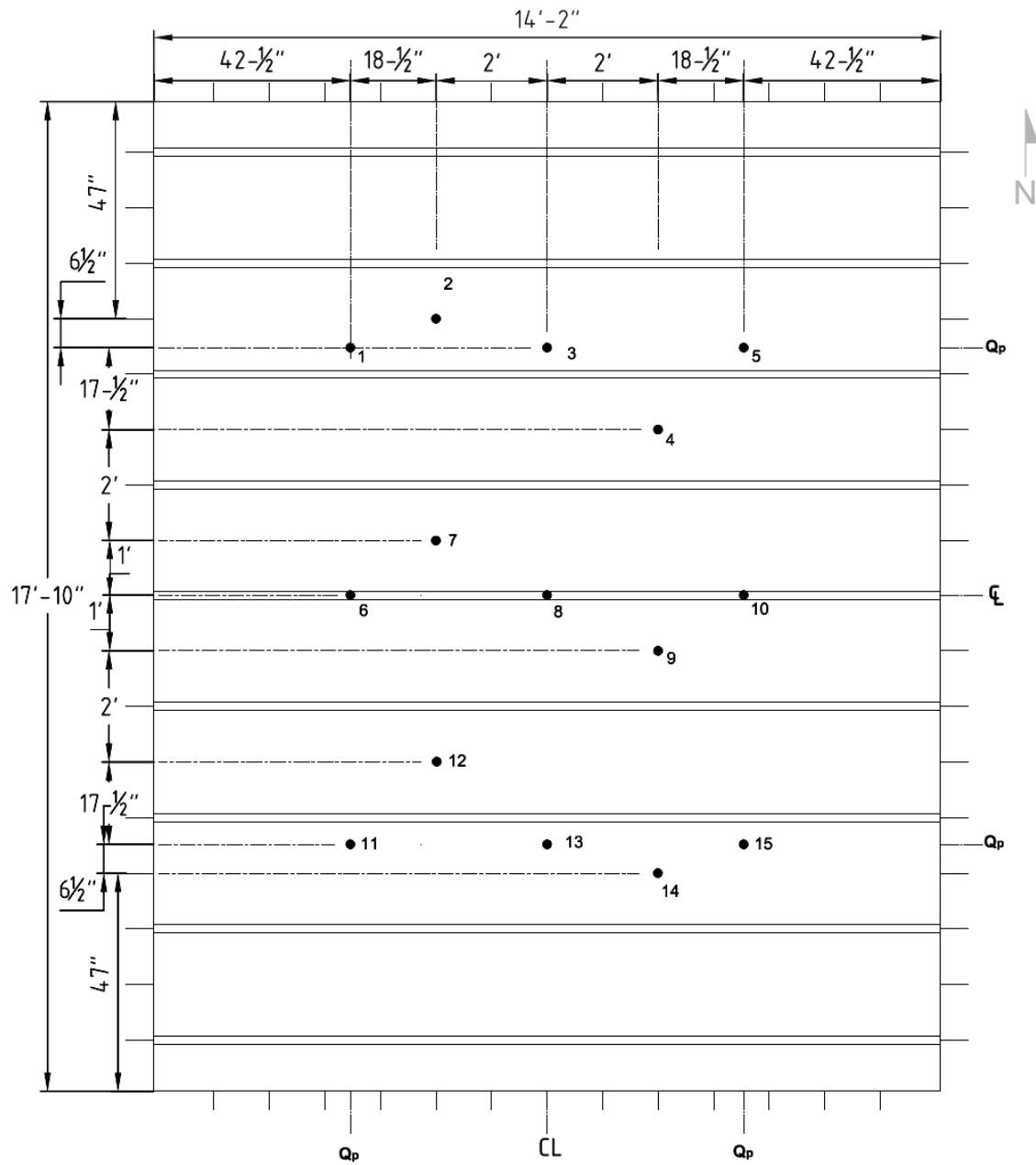

Figure A.2.5 – Thermocouple Locations on Unexposed Surface.

Assembly No. 2

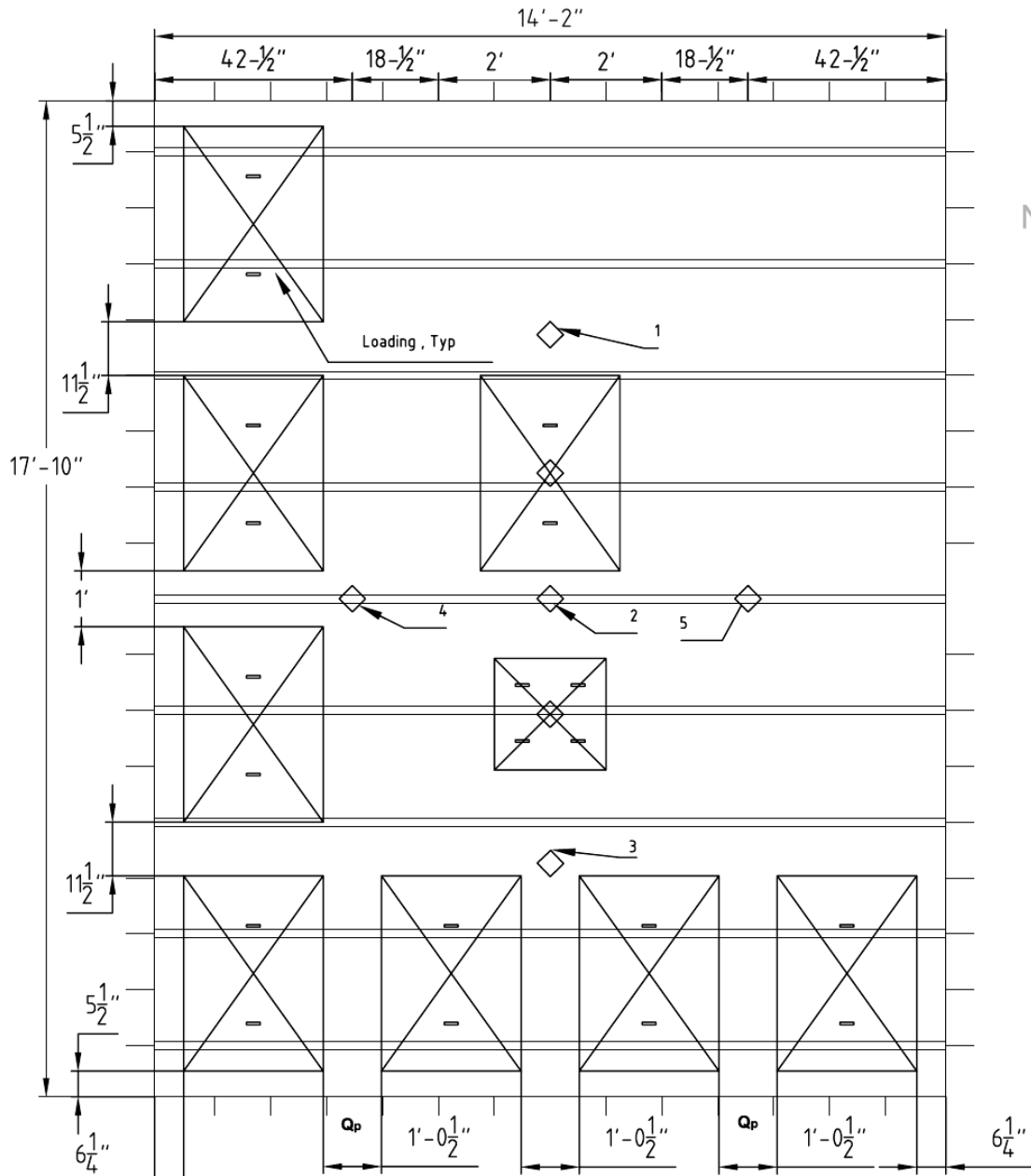

Figure A.2.6 – Loading and Instrumentation Layout (See Figure A.2.7).

**Assembly No. 2**

**Deflection Transducers:**



- 1 - Along E-W Centerline, North Quarter-point.
- 2 - Along E-W Centerline, Center-point.
- 3 - Along E-W Centerline, South Quarter-point.
- 4 - Along N-S Centerline, East Quarter-point.
- 5 - Along N-S Centerline, West Quarter-point.

**Audio Recordings: (Not Shown)**

- 1 - Mannequin No. 1 (Hands & Knees)

**Video Camera Recordings: (Not Shown)**

- Channel 1409 - floor level view from southeast corner
- Channel 1411 - IR camera from curing cell roof east center
- Channel 1412 - furnace camera from northwest corner
- Channel 1416 - overhead from east center of assembly

- Channel 1413 - overhead from south center of assembly
- Channel 1503 - overhead from west center of assembly

**Furnace Pressure Probes: (Not Shown)**

- 1 - located near northeast corner
- 2 - located near southwest corner

**Oxygen Content : (Not Shown)**

located in E exhaust duct.

**Figure A.2.7 – Loading and Instrumentation Key**

Assembly No. 3

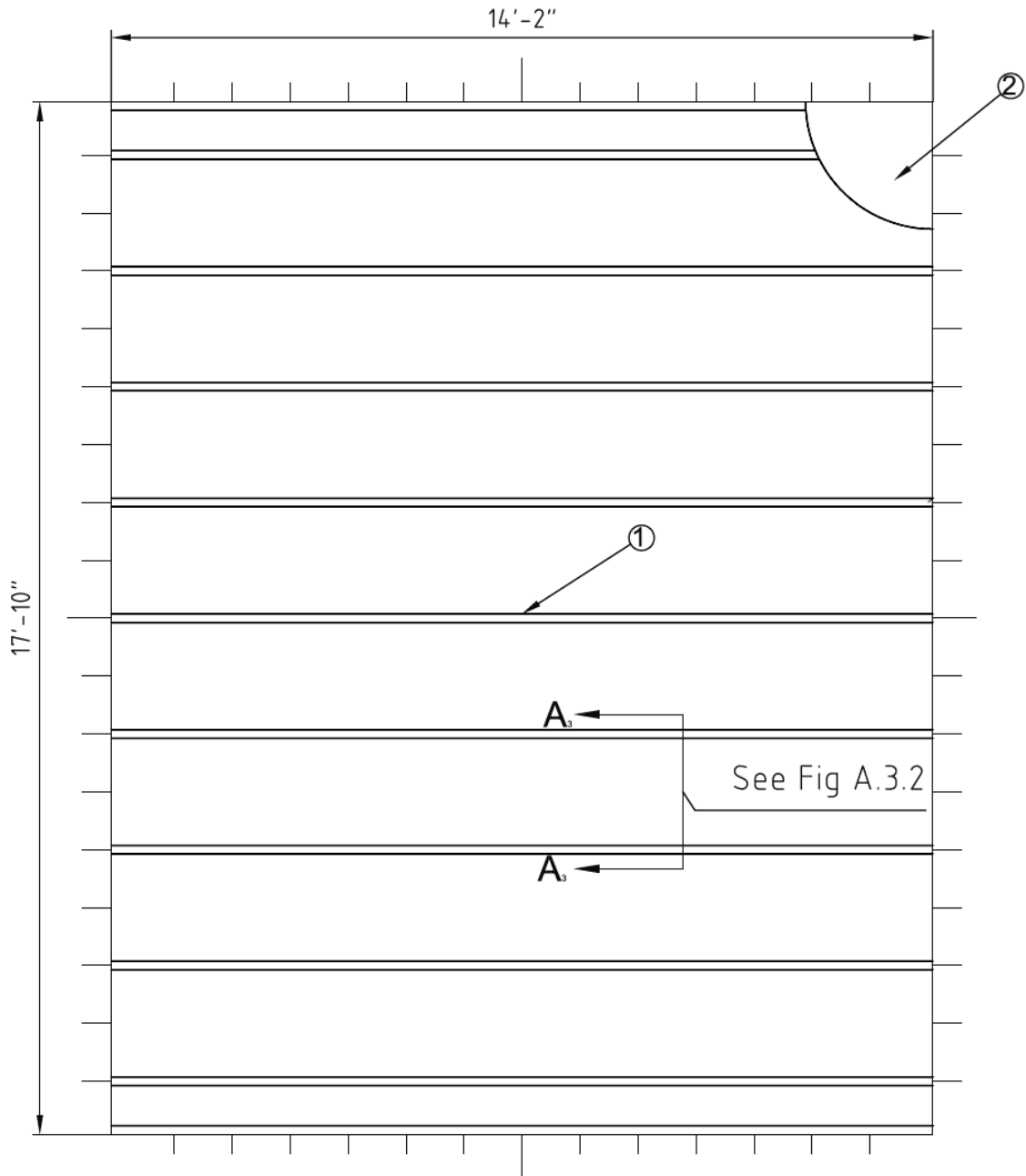
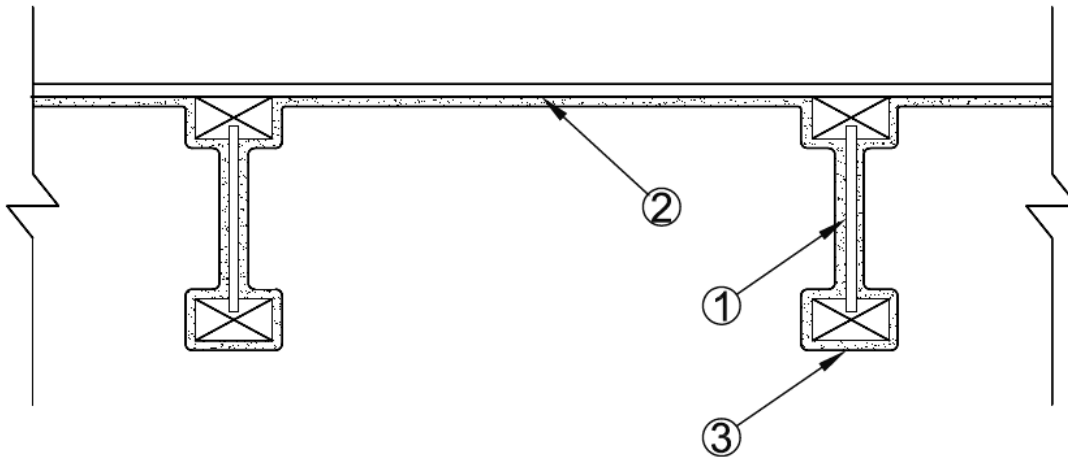

Figure A.3.1 – Construction Layout.

Assembly No. 3



## SECTION A<sub>3</sub>-A<sub>3</sub>

- 1) 11-<sup>7</sup>/<sub>8</sub> in. Deep Engineered I-Joists Spaced 24 in. O.C.
- 2) OSB <sup>23</sup>/<sub>32</sub> in. APA rated sheathing.
- 3) Intumescent Coating Applied to Approx. 65 mils.

Figure A.3.2 – Construction Layout Section A<sub>3</sub>-A<sub>3</sub>.



Assembly No. 3

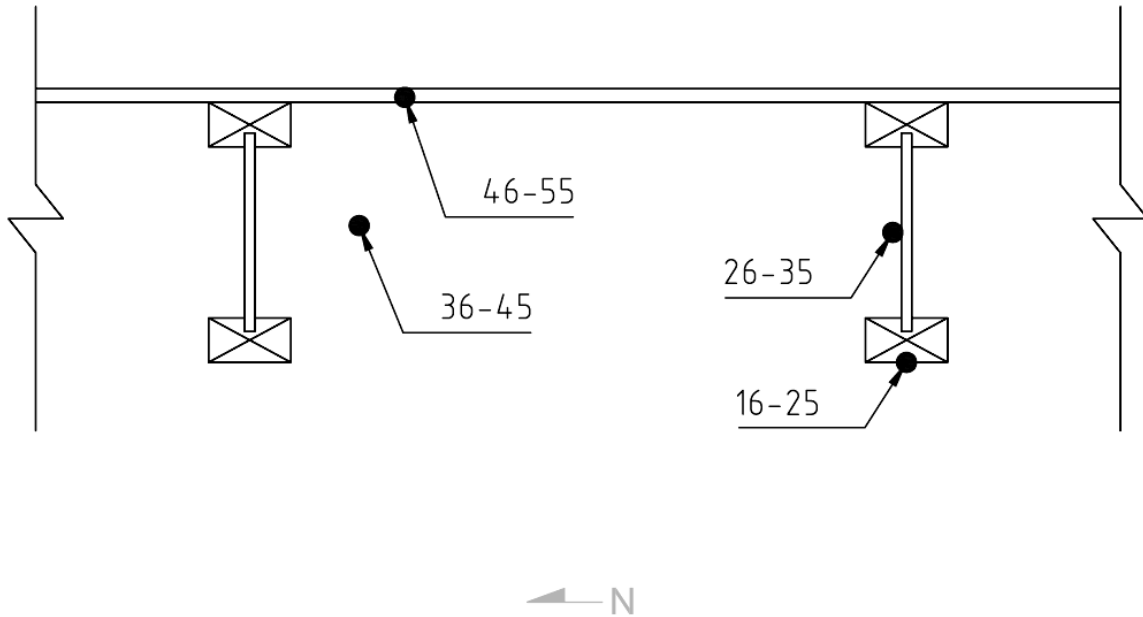

## Elevation - Thermocouple Location

Engineered I-Joists w/ Intumescent Coating,  
Plenum, bottom of Sub Floor

TC # LOCATION

16-25 On Bottom of Engineered I-Joist

26-35 On Side of Engineered I-Joist at Mid Depth, Facing North

36-45 Mid Depth Between Engineered I-Joists

46-55 On Bottom of Subfloor

Figure A.3.3 – Thermocouple Locations - Elevation.

Assembly No. 3

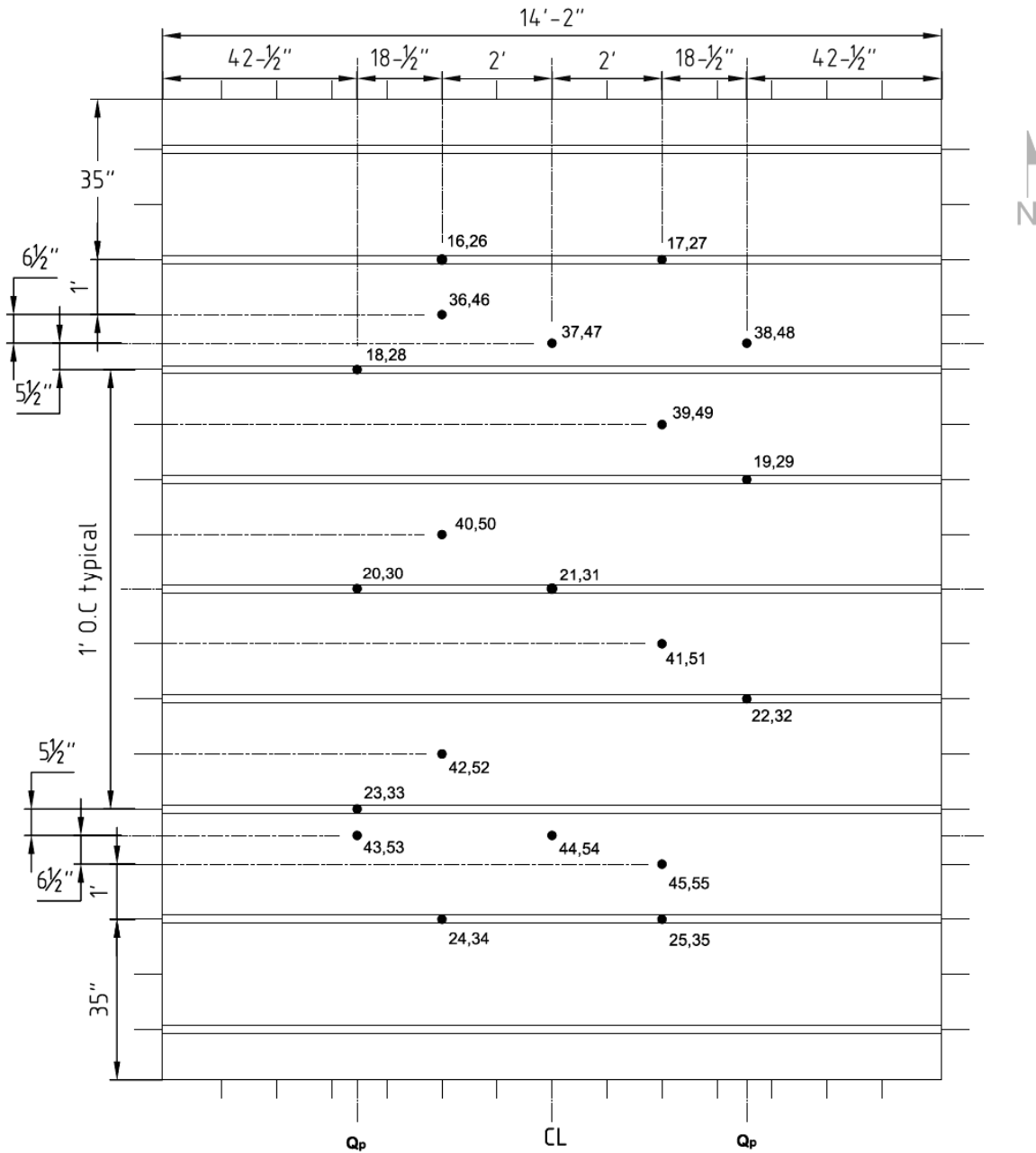

Figure A.3.4 – Thermocouple Locations on Exposed Surface.

Assembly No. 3

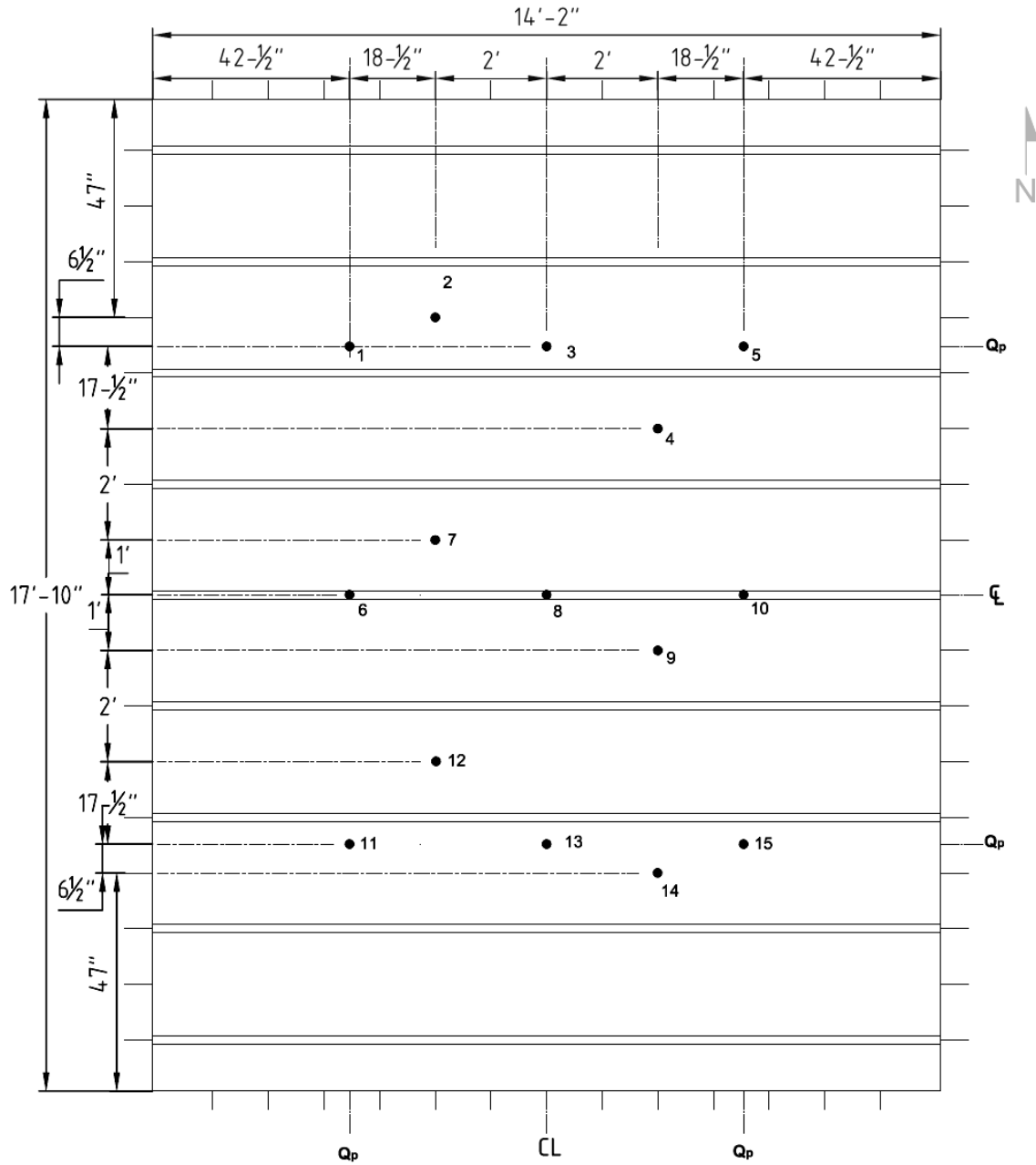

Figure A.3.5 – Thermocouple Locations on Unexposed Surface.

Assembly No. 3

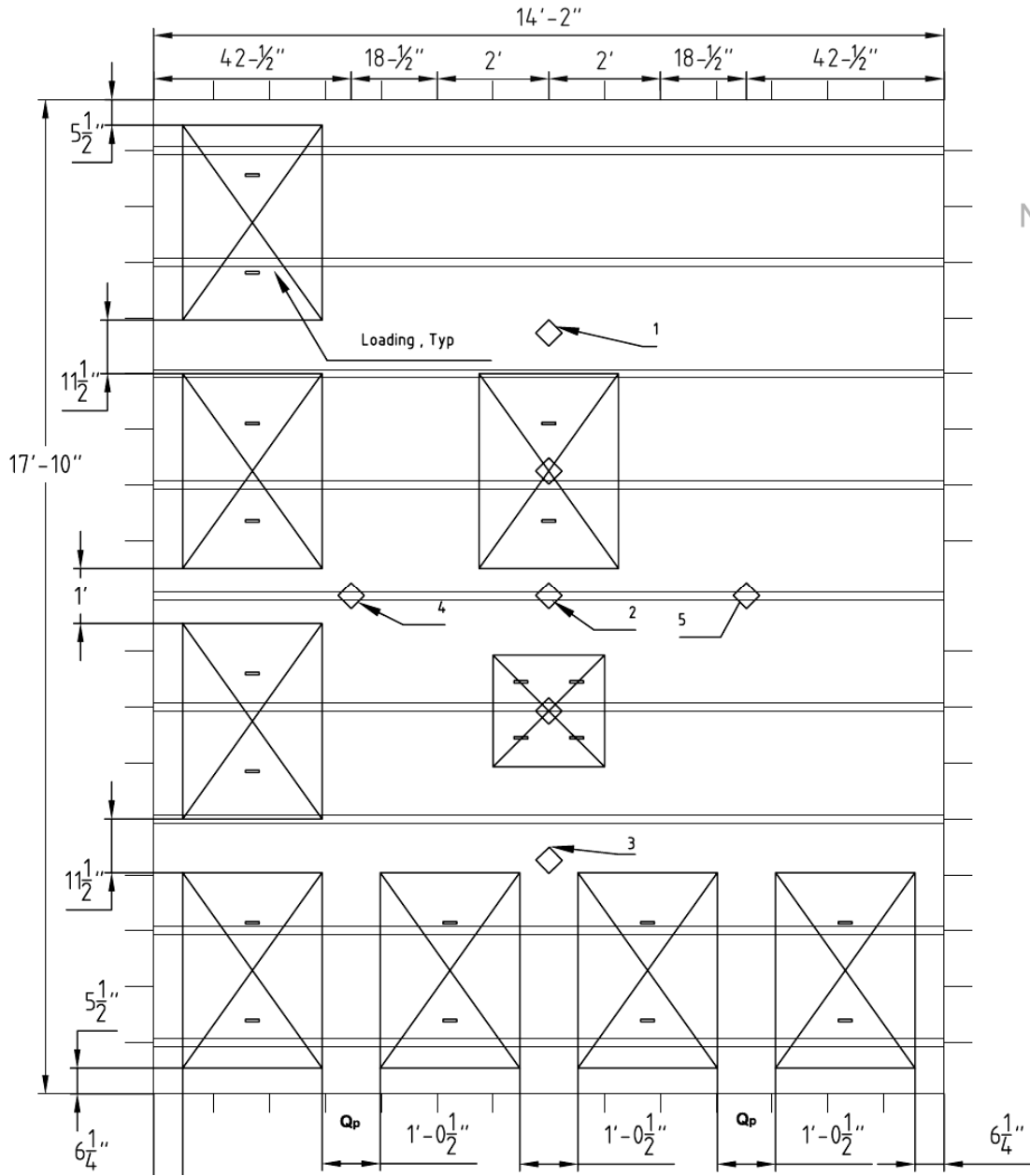

Figure A.3.6 – Loading and Instrumentation Layout (See Figure A.3.7).

**Assembly No. 3**

**Deflection Transducers:**



- 1 - Along E-W Centerline, North Quarter-point.
- 2 - Along E-W Centerline, Center-point.
- 3 - Along E-W Centerline, South Quarter-point.
- 4 - Along N-S Centerline, East Quarter-point.
- 5 - Along N-S Centerline, West Quarter-point.

**Audio Recordings: (Not Shown)**

- 1 - Mannequin No. 1 (Hands & Knees)

**Video Camera Recordings: (Not Shown)**

- Channel 1409 - floor level view from southeast corner
- Channel 1411 - IR camera from curing cell roof east center
- Channel 1412 - furnace camera from northwest corner
- Channel 1416 - overhead from east center of assembly
  
- Channel 1413 - overhead from south center of assembly
- Channel 1503 - overhead from west center of assembly

**Furnace Pressure Probes: (Not Shown)**

- 1 - located (36 in. off east edge and 42 in. off north edge)
- 2 - located (36 in. off west edge and 42 in. off south edge)

**Oxygen Content : (Not Shown)**

located in E exhaust duct.

**Figure A.3.7 – Loading and Instrumentation Key**

Assembly No. 4

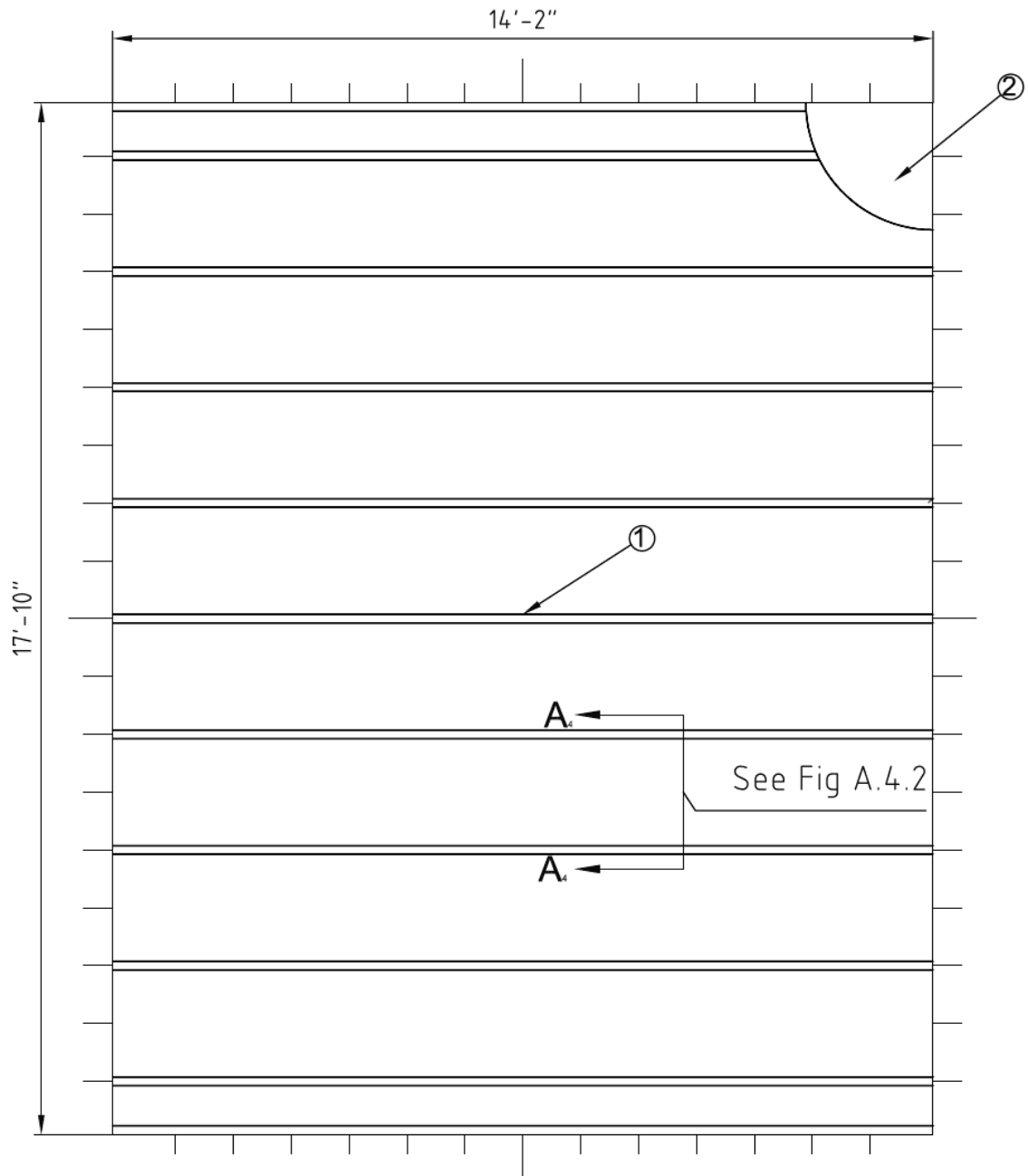
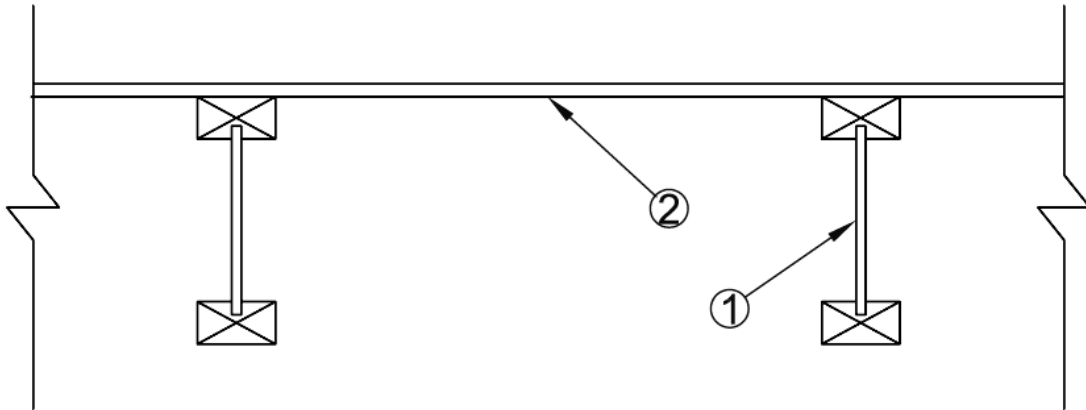

Figure A.4.1 – Construction Layout

Assembly No. 4



## SECTION A<sub>4</sub>-A<sub>4</sub>

- 1) 11-<sup>7</sup>/<sub>8</sub> in. Deep Engineered I-Joists Spaced 24 in. O.C.
- 2) OSB <sup>23</sup>/<sub>32</sub> in. APA rated sheathing.

Figure A.4.2 – Construction Layout Section A<sub>4</sub>-A<sub>4</sub>.

Assembly No. 4

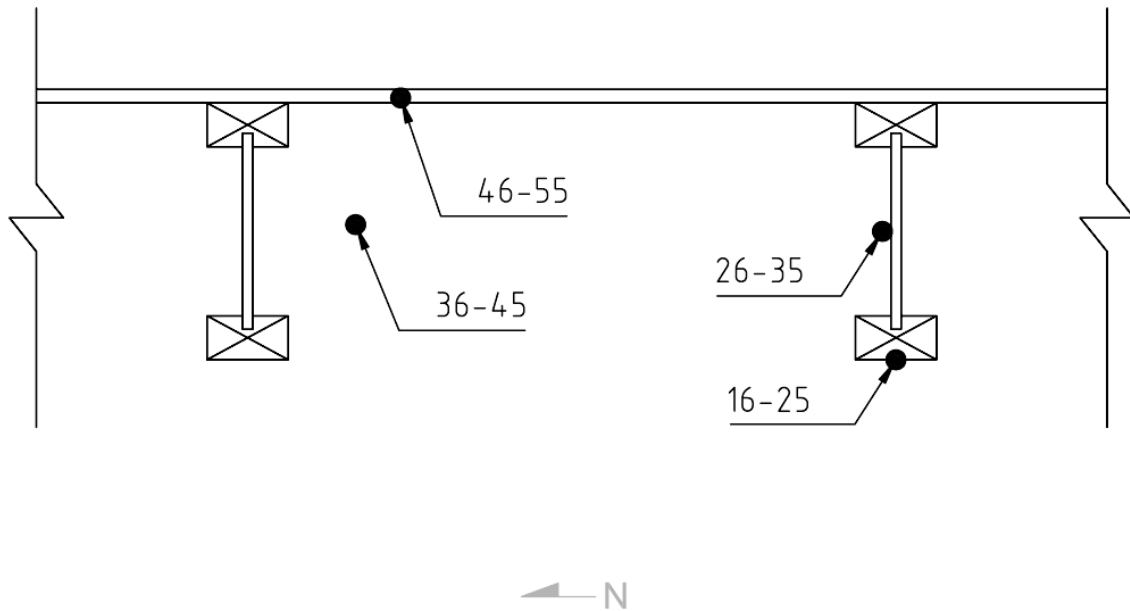

## Elevation - Thermocouple Location

Engineered I-Joists, Plenum, Bottom of Sub Floor

TC # LOCATION

16-25 On Bottom of Engineered I-Joist

26-35 On Side of Engineered I-Joists at Mid Depth, Facing North

36-45 Mid Depth Between I-Joists

46-55 On Bottom of Subfloor

Figure A.4.3 – Thermocouple Locations - Elevation.



Assembly No. 4

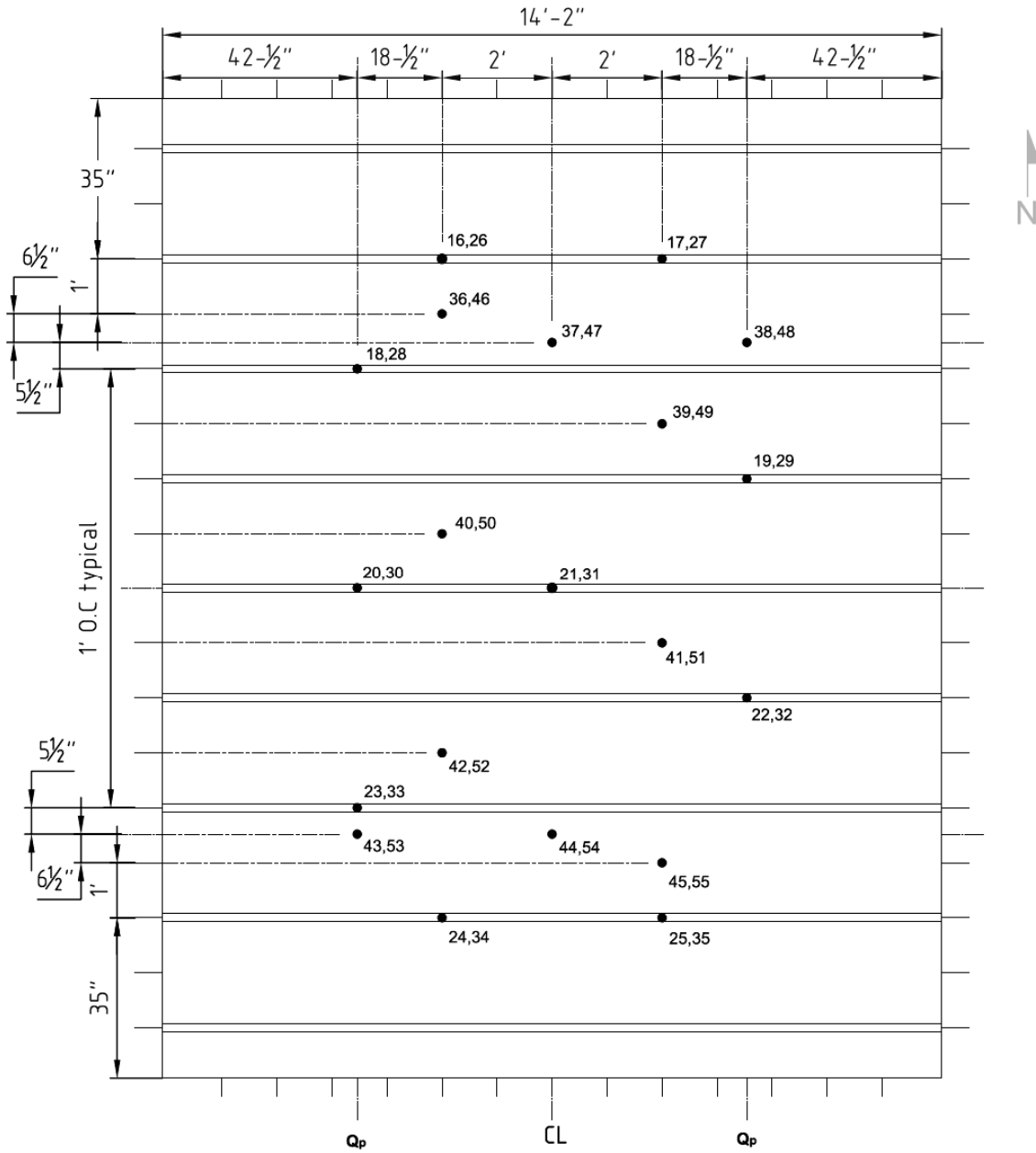

Figure A.4.4 – Thermocouple Locations on Exposed Surface.

Assembly No. 4

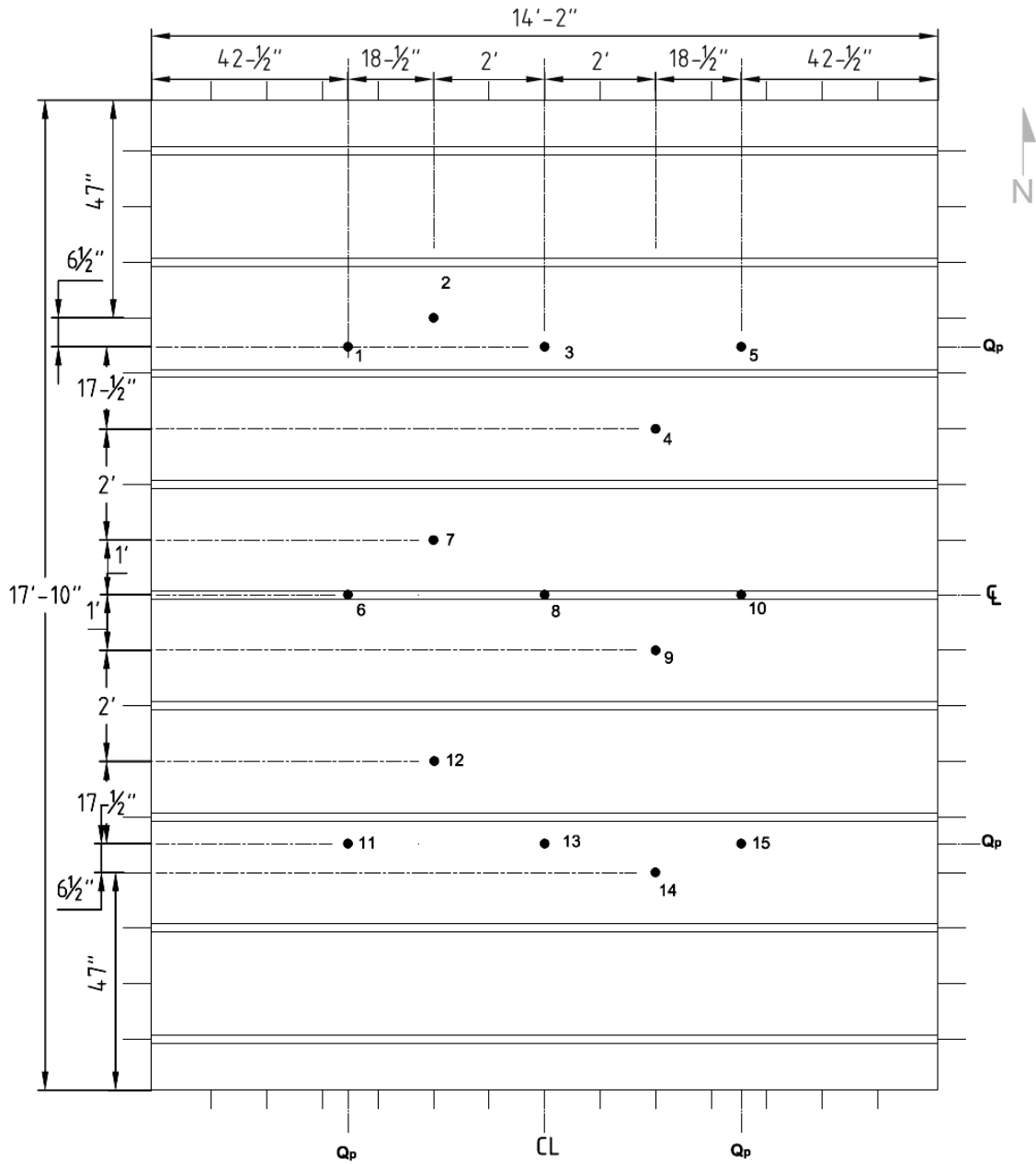

Figure A.4.5 – Thermocouple Locations on Unexposed Surface.

Assembly No. 4

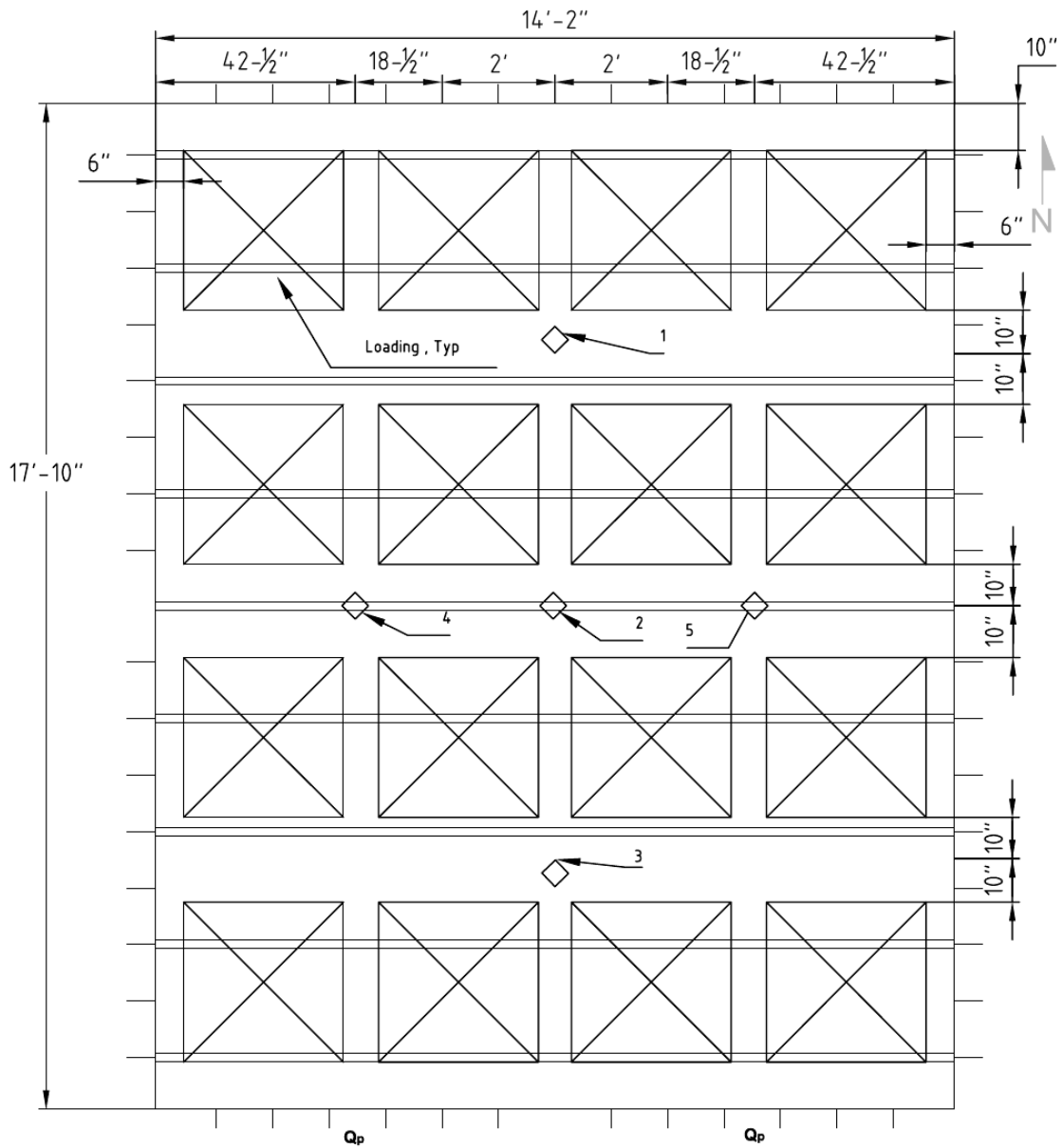

Figure A.4.6 – Loading and Instrumentation Layout (See Figure A.4.7).

**Assembly No. 4**

**Deflection Transducers:**

- 1 - Along E-W Centerline, North Quarter-point.
- 2 - Along E-W Centerline, Center-point.
- 3 - Along E-W Centerline, South Quarter-point.
- 4 - Along N-S Centerline, East Quarter-point.
- 5 - Along N-S Centerline, West Quarter-point.

**Audio Recordings: (Not Shown)**

- 1 - At center of assembly hanging 24 in. above subfloor.

**Video Camera Recordings: (Not Shown)**

- Channel 1409 - floor level view from southeast corner
- Channel 1411 - IR camera from curing cell roof east center
- Channel 1412 - furnace camera from northwest corner
- Channel 1416 - overhead from east center of assembly
  
- Channel 1413 - overhead from south center of assembly
- Channel 1503 - overhead from west center of assembly

**Furnace Pressure Probes: (Not Shown)**

- 1 - located near northeast corner
- 2 - located near southwest corner

**Oxygen Content : (Not Shown)**

located in E exhaust duct.

**Figure A.4.7 – Loading and Instrumentation Key**

Assembly No. 5

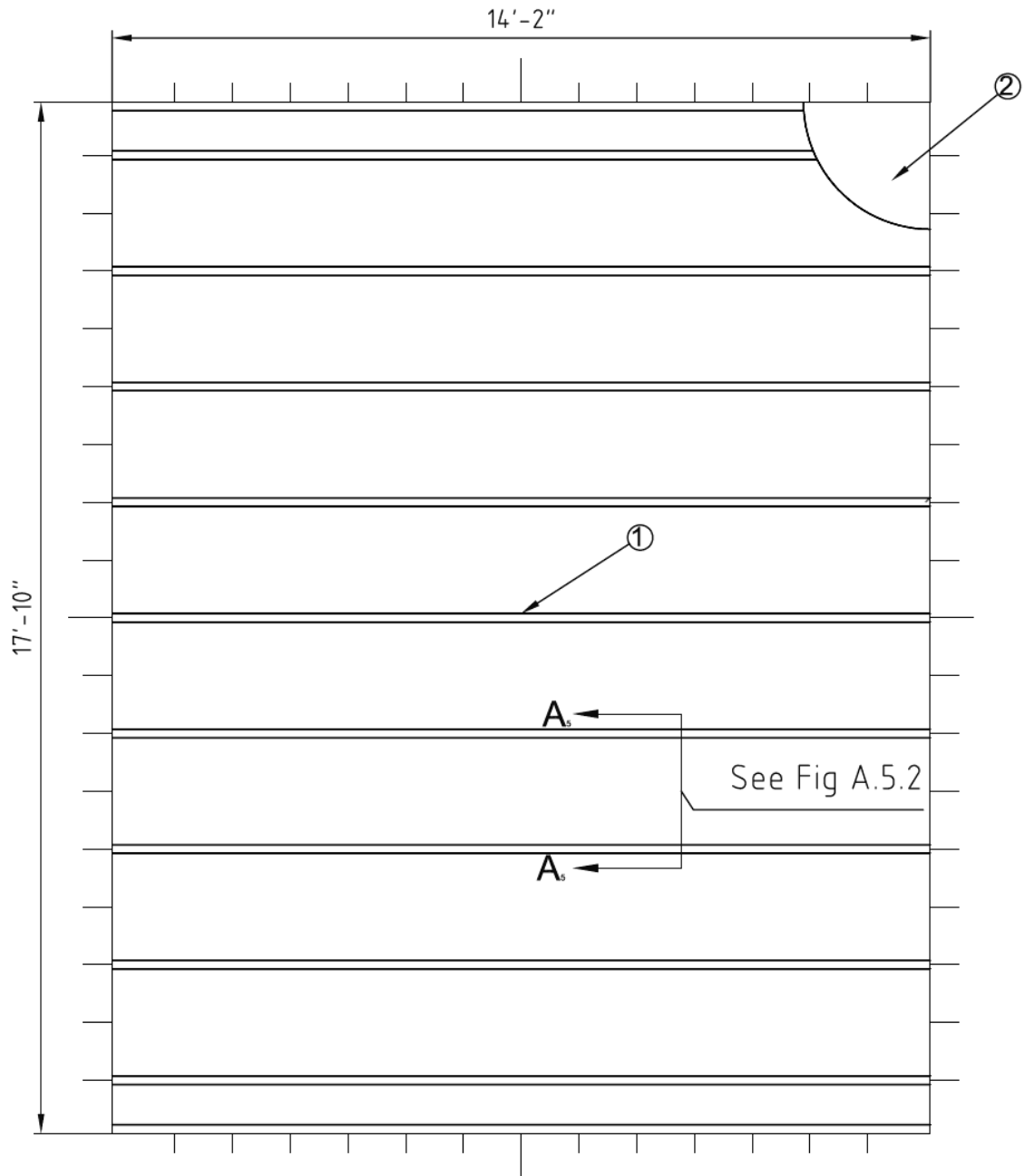
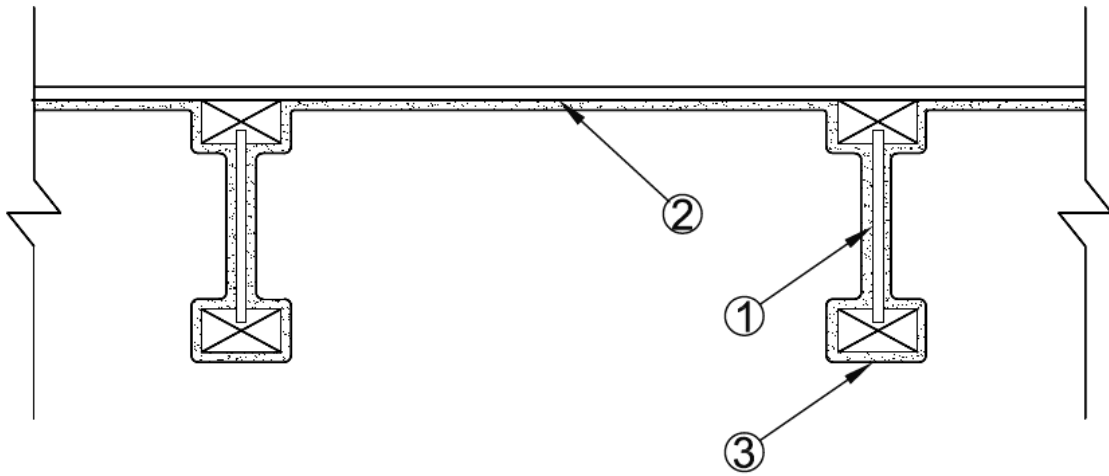

Figure A.5.1 – Construction Layout

Assembly No. 5



## SECTION A<sub>5</sub>-A<sub>5</sub>

- 1) 11-<sup>7</sup>/<sub>8</sub> in. Deep Engineered I-Joists Spaced 24 in. O.C.
- 2) OSB <sup>23</sup>/<sub>32</sub> in. APA rated sheathing.
- 3) Fire Retardant Coating Applied at Approx. 15 mils.

Figure A.5.2 – Construction Layout Section A<sub>5</sub>-A<sub>5</sub>.

Assembly No. 5

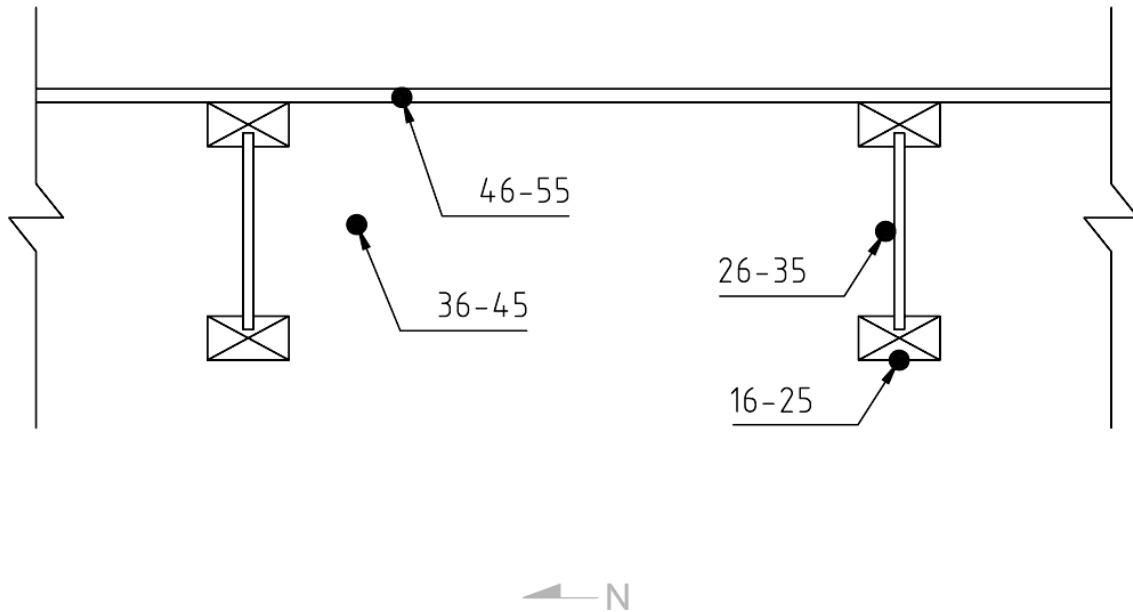

## Elevation - Thermocouple Location

Engineered I-Joists, Plenum, bottom of Sub Floor

### TC # LOCATION

16-25 On Bottom of Engineered I-Joist

26-35 On Side of Engineered I-Joist at Mid Depth, Facing North

36-45 Mid Depth Between I-Joists

46-55 On Bottom of Subfloor

**Figure A.5.3 – Thermocouple Locations - Elevation.**

Assembly No. 5

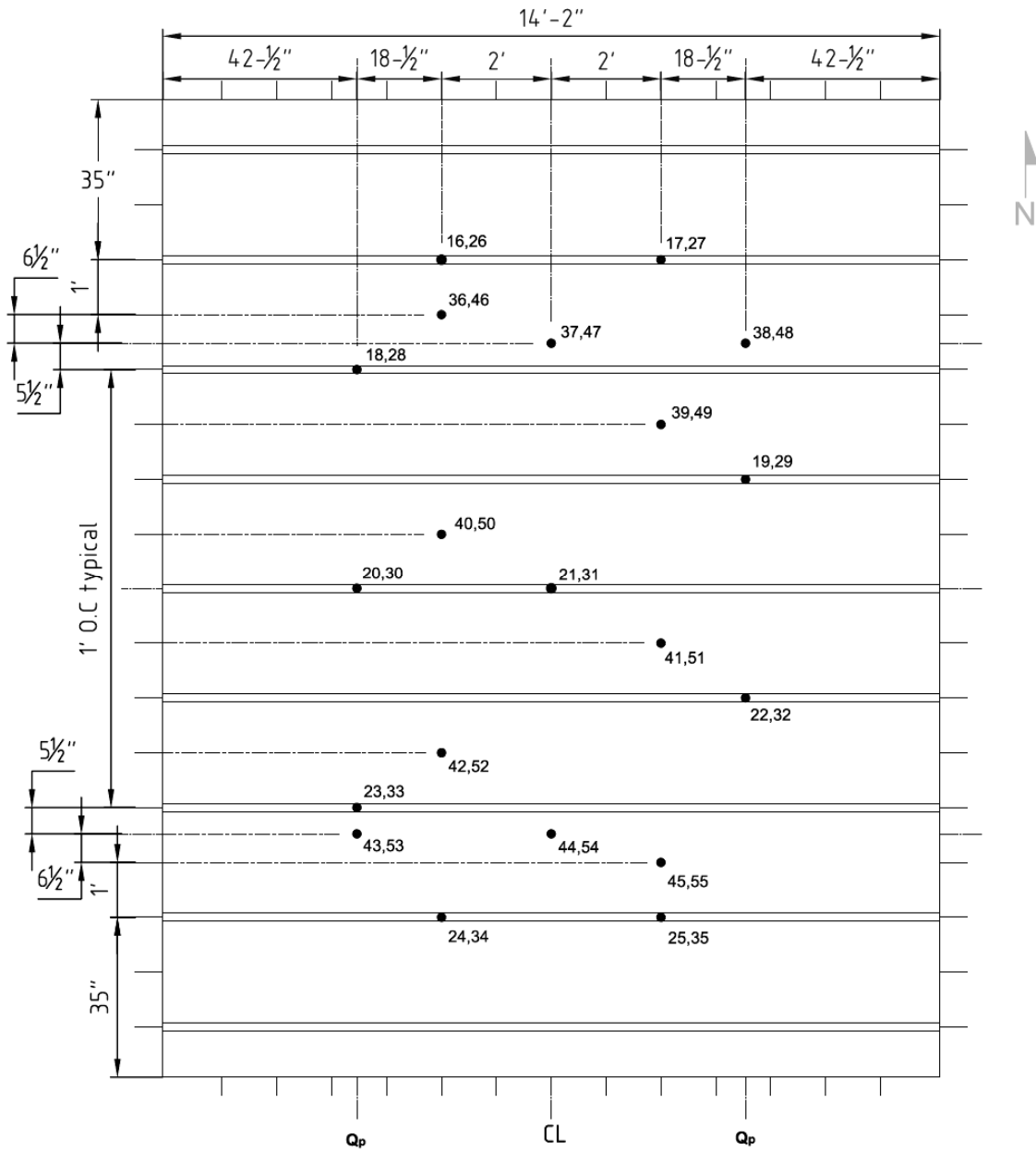

Figure A.5.4 – Thermocouple Locations on Exposed Surface.



Assembly No. 5

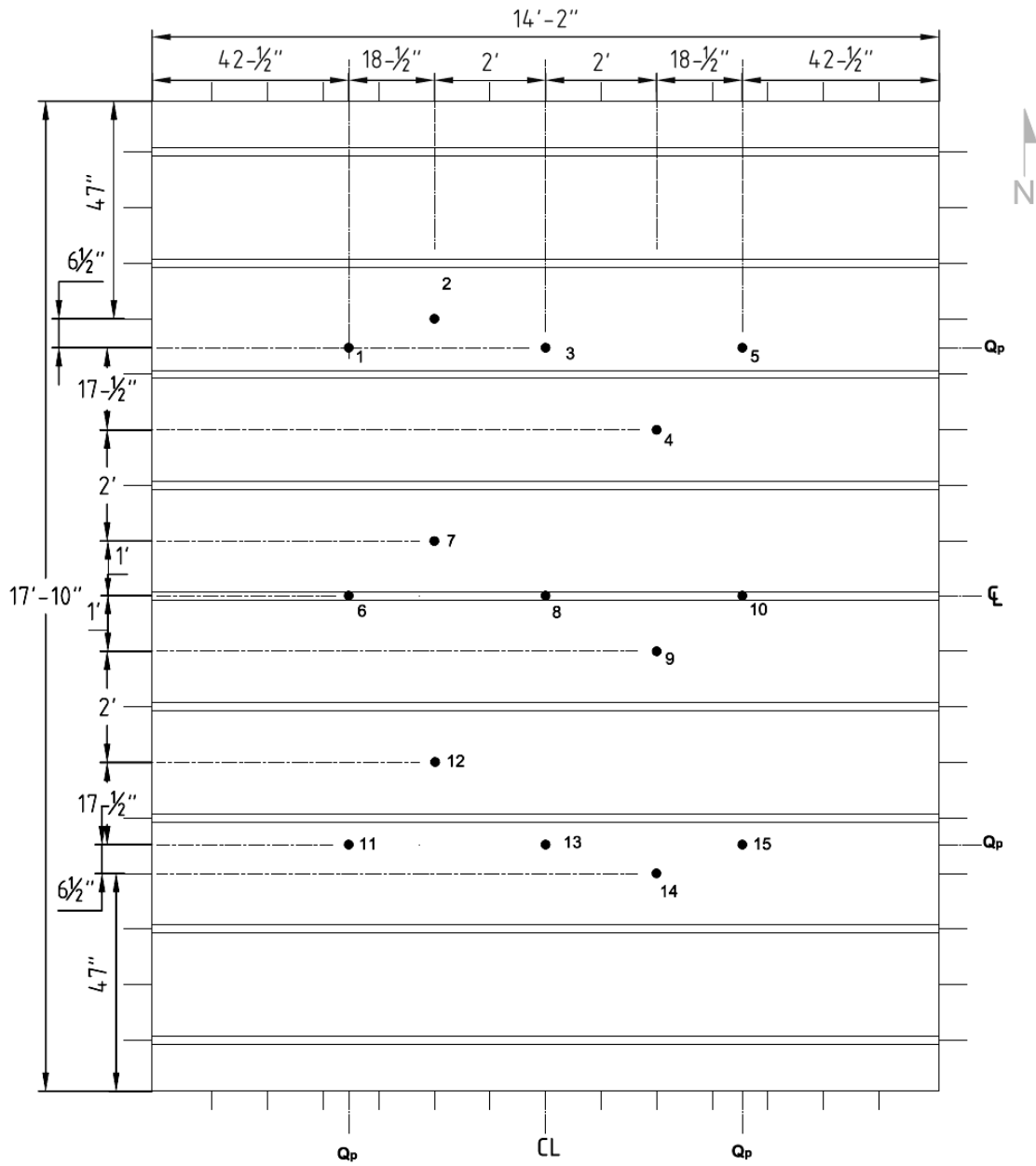

Figure A.5.5 – Thermocouple Locations on Unexposed Surface

Assembly No. 5

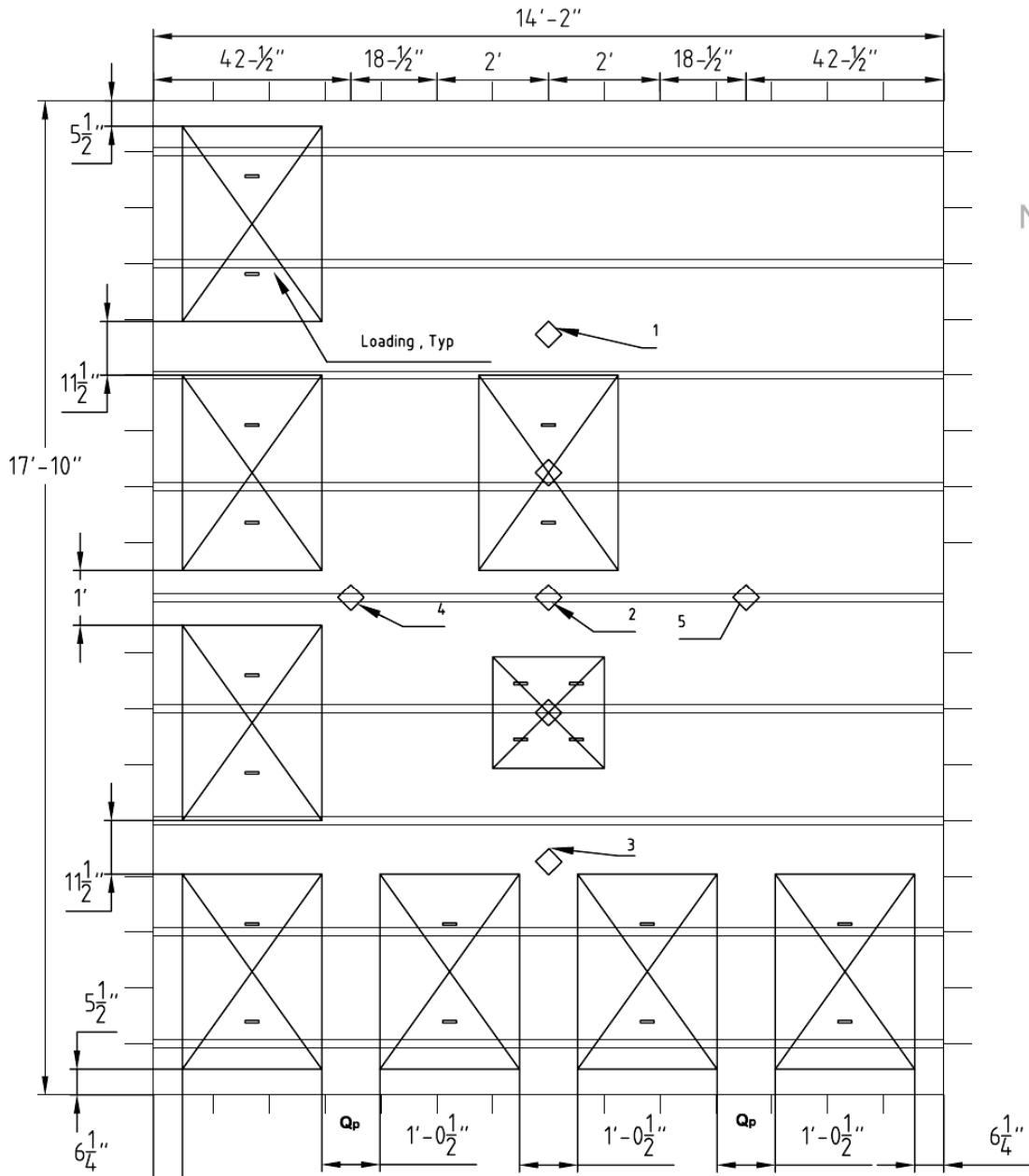

Figure A.5.6 – Loading and Instrumentation Layout (See Figure A.5.7).

**Assembly No. 5**

**Deflection Transducers:**



- 1 - Along E-W Centerline, North Quarter-point.
- 2 - Along E-W Centerline, Center-point.
- 3 - Along E-W Centerline, South Quarter-point.
- 4 - Along N-S Centerline, East Quarter-point.
- 5 - Along N-S Centerline, West Quarter-point.

**Audio Recordings: (Not Shown)**

- 1 - Mannequin No. 1 (Hands & Knees)

**Video Camera Recordings: (Not Shown)**

- Channel 1409 - floor level view from southeast corner
- Channel 1411 - IR camera from curing cell roof east center
- Channel 1412 - furnace camera from northwest corner
- Channel 1416 - overhead from east center of assembly
  
- Channel 1413 - overhead from south center of assembly
- Channel 1503 - overhead from west center of assembly

**Furnace Pressure Probes: (Not Shown)**

- 1 - located (36 in. off east edge and 42 in. off north edge)
- 2 - located (36 in. off west edge and 42 in. off south edge)

**Oxygen Content : (Not Shown)**

located in E exhaust duct.

**Figure A.5.7 – Loading and Instrumentation Key**

Assembly No. 6

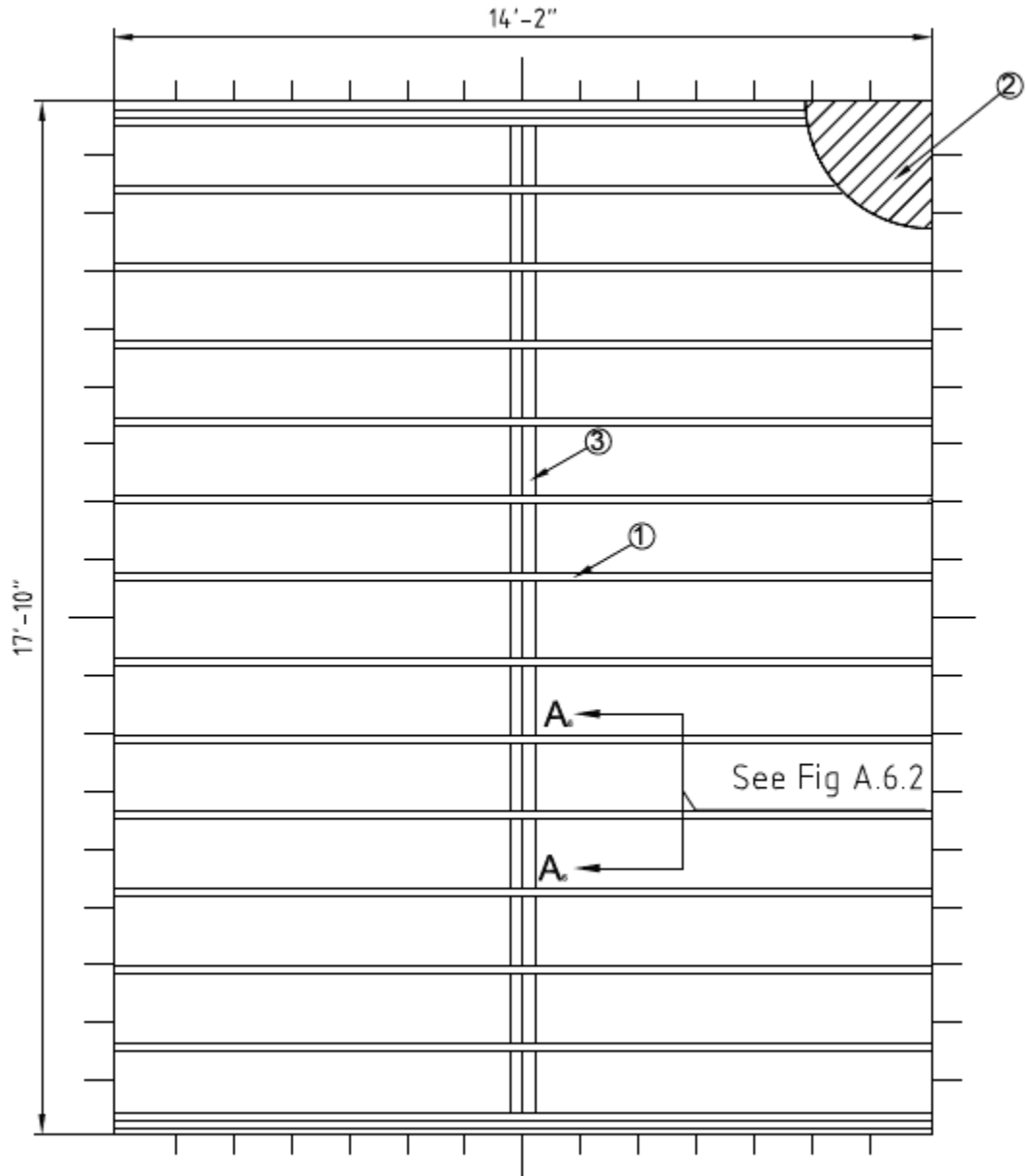
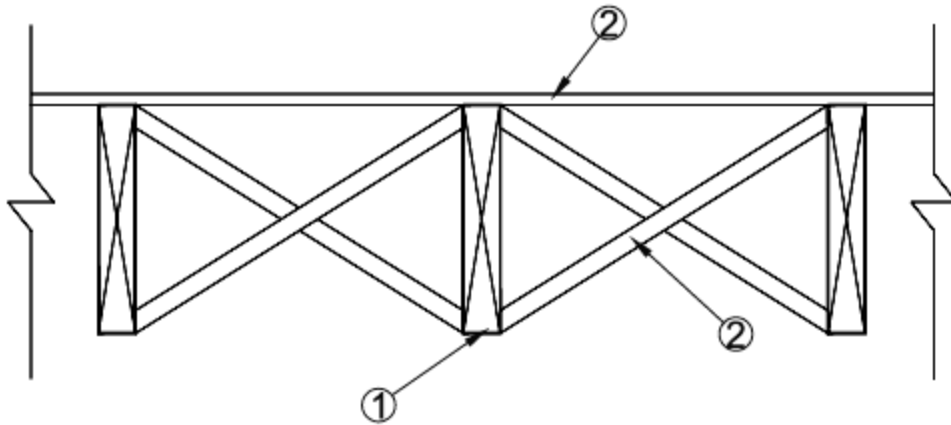

Figure A.6.1 – Construction Layout

Assembly No. 6



SECTION A<sub>6</sub>-A<sub>6</sub>

- 1) 2 in. x 10 in. joists spaced 16 in. O.C.
- 2) 1 in. x 3 in. cross bridging.
- 3) OSB <sup>23</sup>/<sub>32</sub> in. T&G APA rated sheathing.

Figure A.6.2 – Construction Layout Section A<sub>6</sub>-A<sub>6</sub>.

Assembly No. 6

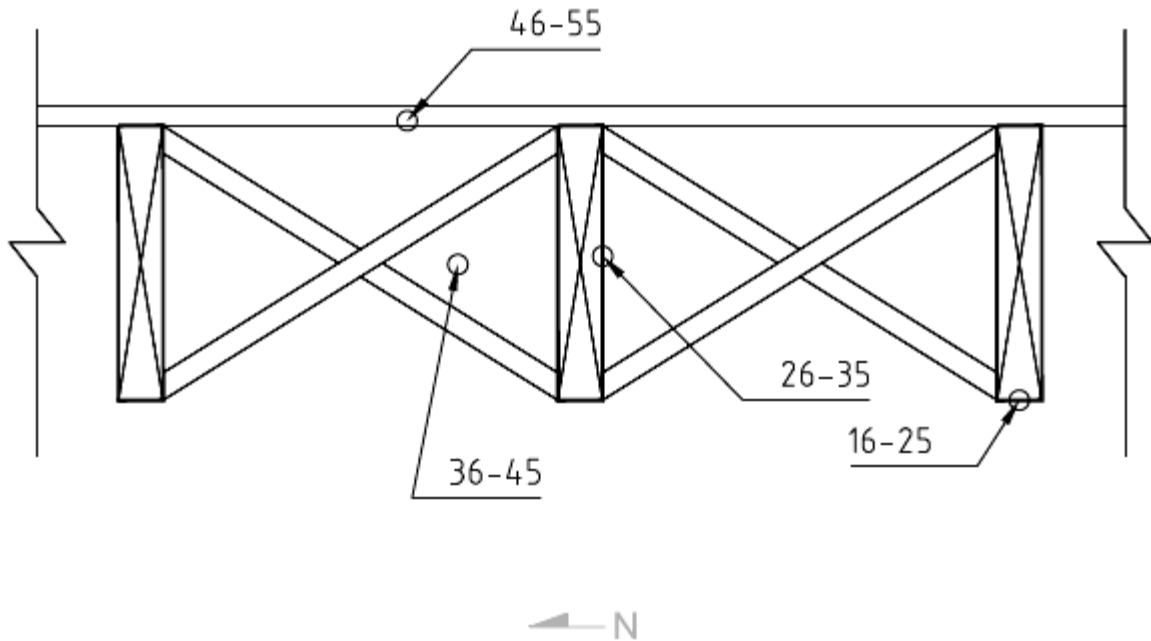

## Elevation - Thermocouple Location

Joist, Plenum, Bottom of Sub Floor

### TC # LOCATION

16-25 On Bottom of joist

26-35 On Side of joist at Mid Depth, Facing North

36-45 Mid Depth Between joist

46-55 On Bottom of Subfloor

Figure A.6.3 – Thermocouple Locations - Elevation.

Assembly No. 6

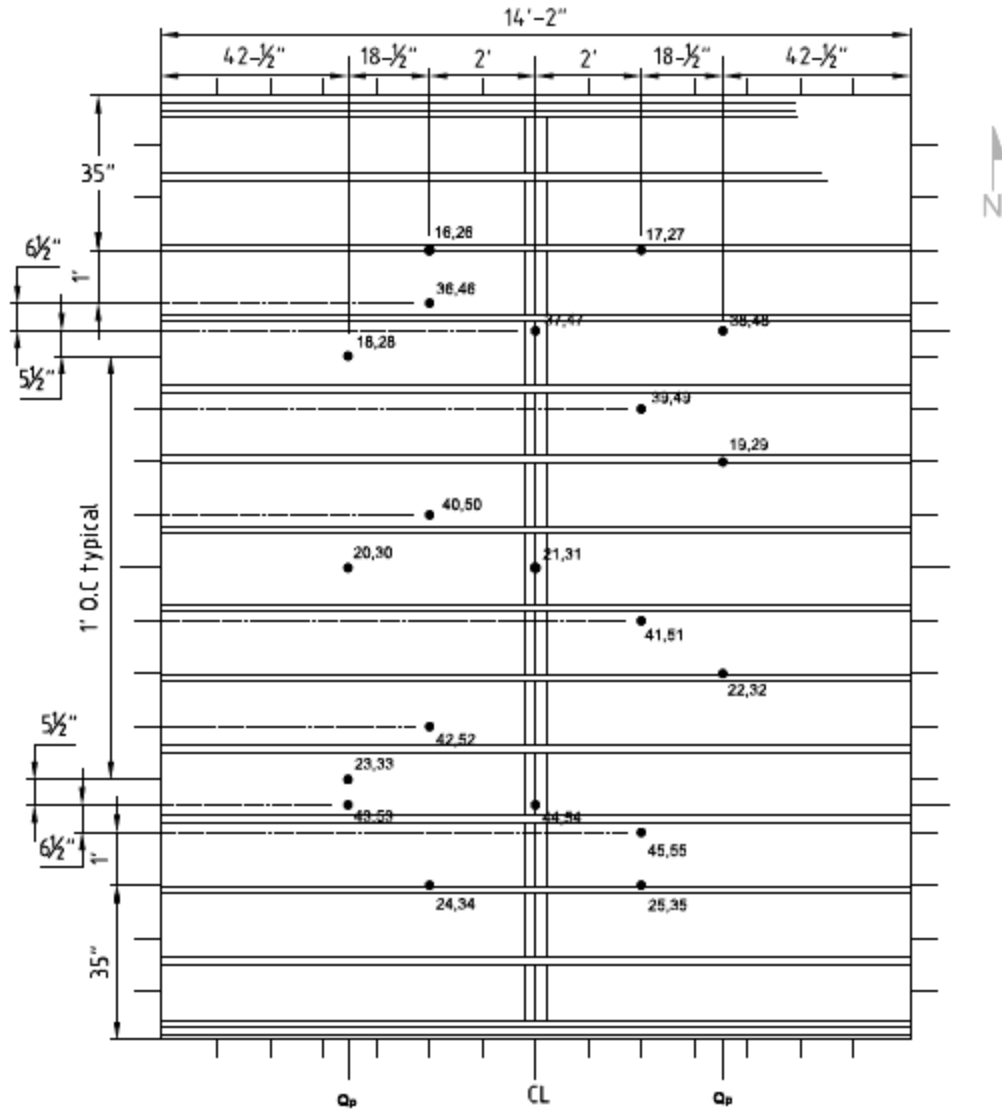

Figure A.6.4 – Thermocouple Locations on Exposed Surface.

Assembly No. 6

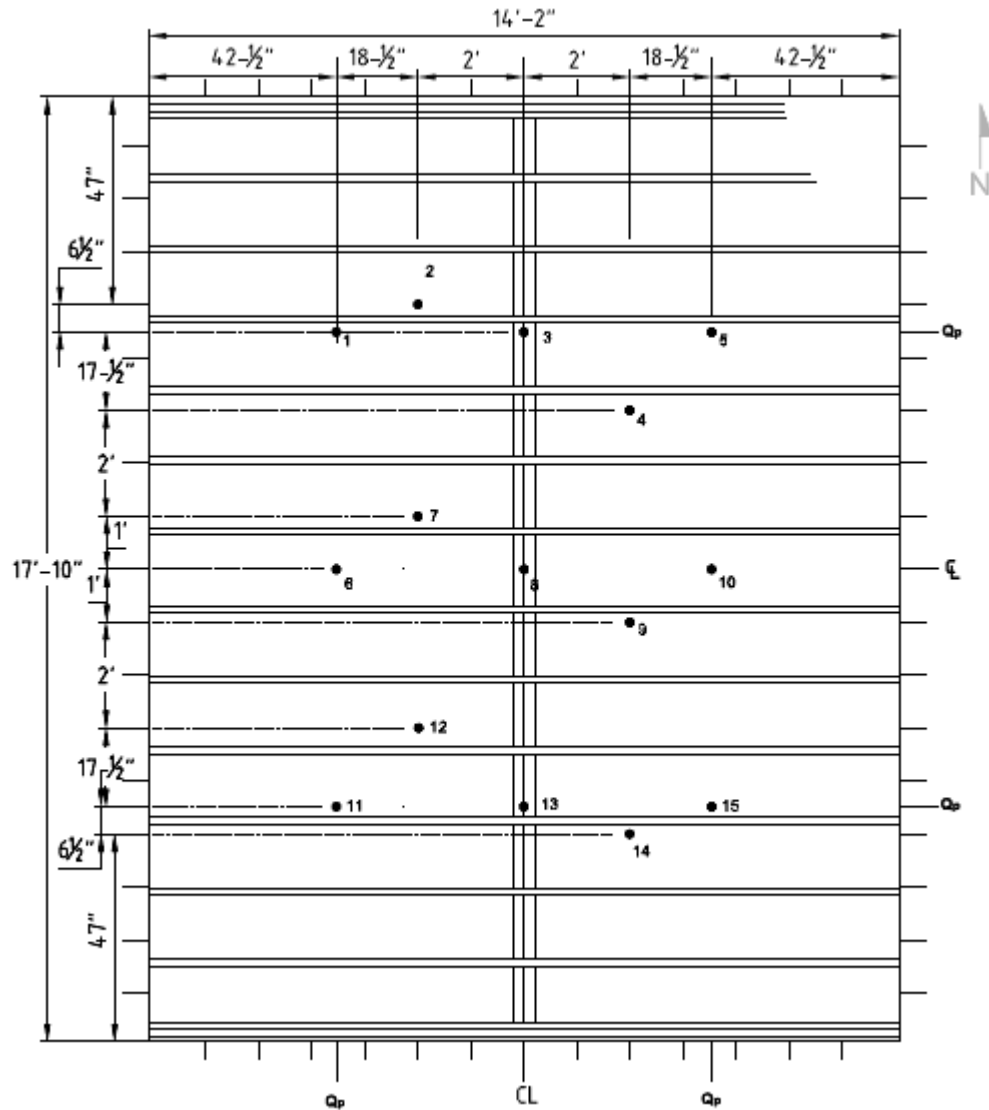

Figure A.6.5 – Thermocouple Locations on Unexposed Surface



Assembly No. 6

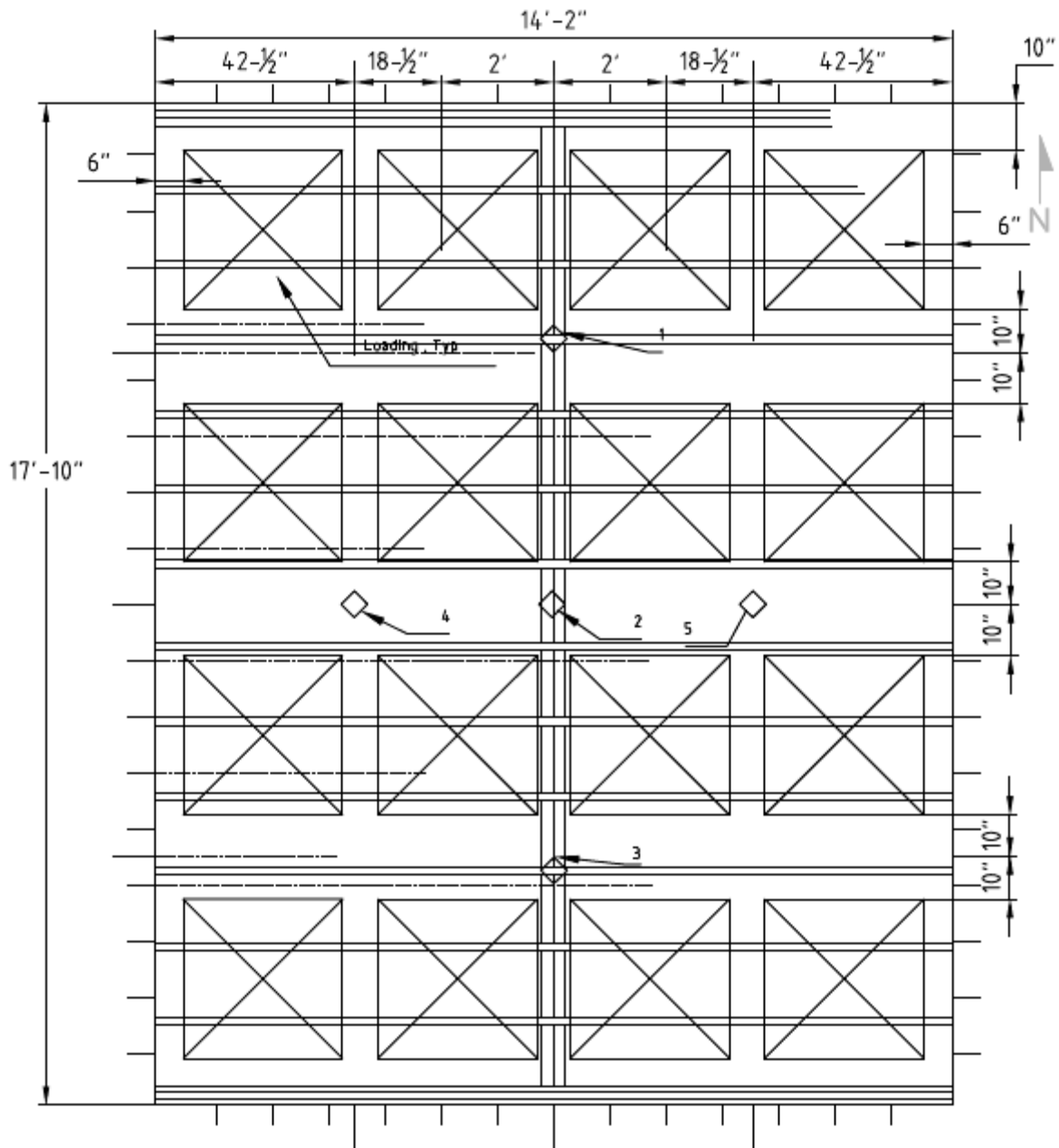

Figure A.6.6 – Loading and Instrumentation Layout (See Figure A.6.7).

**Assembly No. 6**

**Deflection Transducers:**



- 1 - Along E-W Centerline, North Quarter-point.
- 2 - Along E-W Centerline, Center-point.
- 3 - Along E-W Centerline, South Quarter-point.
- 4 - Along N-S Centerline, East Quarter-point.
- 5 - Along N-S Centerline, West Quarter-point.

**Audio Recordings: (Not Shown)**

- 1 - At center of assembly hanging 24 in. above subfloor.

**Video Camera Recordings: (Not Shown)**

- Channel 1409 - floor level view from southeast corner
- Channel 1411 - IR camera from curing cell roof east center
- Channel 1412 - furnace camera from northwest corner
- Channel 1416 - overhead from east center of assembly
  
- Channel 1413 - overhead from south center of assembly
- Channel 1503 - overhead from west center of assembly

**Furnace Pressure Probes: (Not Shown)**

- 1 - located near northeast corner
- 2 - located near southwest corner

**Oxygen Content : (Not Shown)**

located in E exhaust duct.

**Figure A.6.7 – Loading and Instrumentation Key**

Assembly No. 7

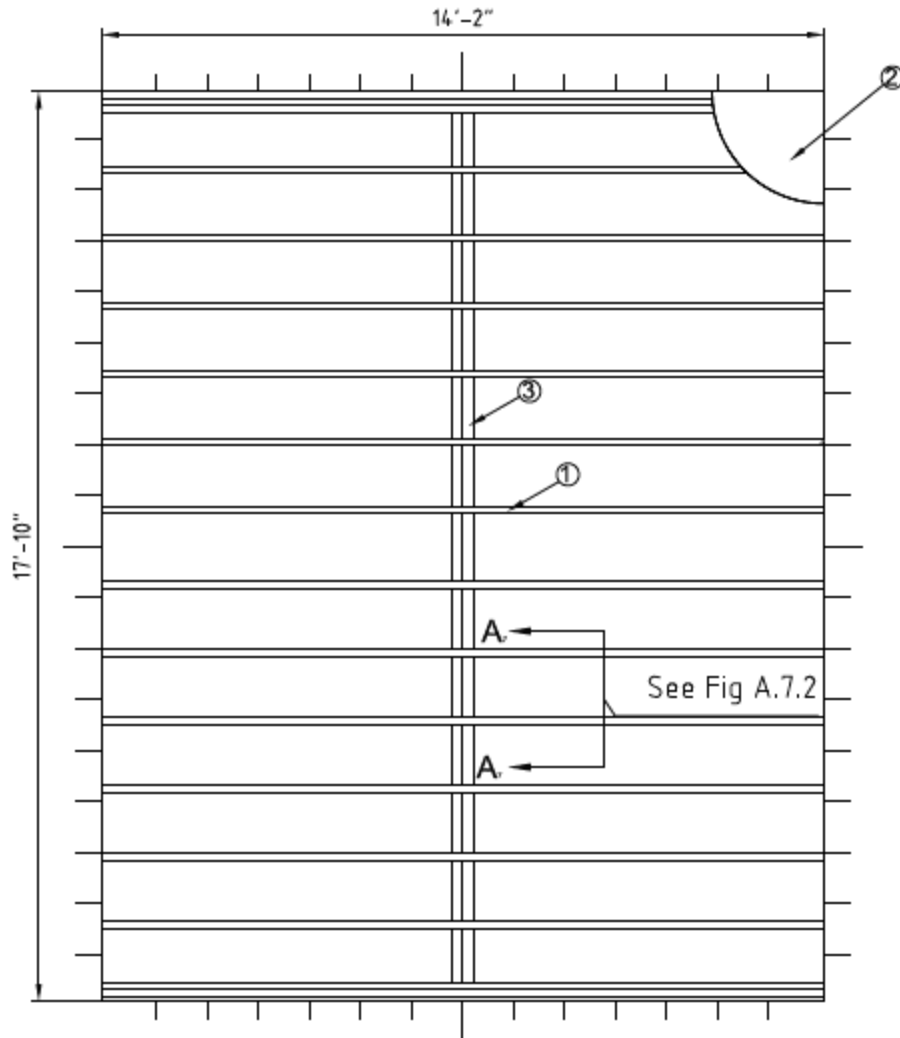
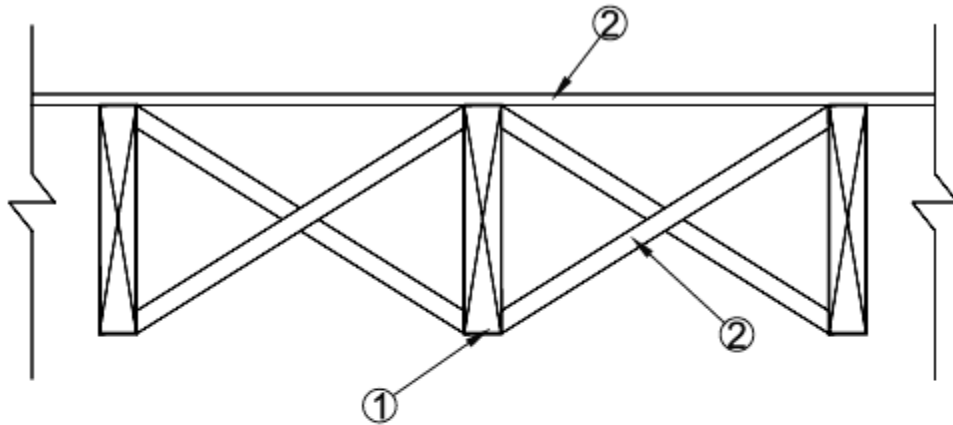

Figure A.7.1 – Construction Layout

Assembly No. 7



SECTION A<sub>7</sub>-A<sub>7</sub>

- 1) 2 in. x 8 in. joists spaced 16 in. O.C.
- 2) 1 in. x 3 in. cross bridging.
- 3) OSB <sup>23</sup>/<sub>32</sub> in. T&G APA rated sheathing.

Figure A.7.2 – Construction Layout Section A<sub>7</sub>-A<sub>7</sub>.

Assembly No. 7

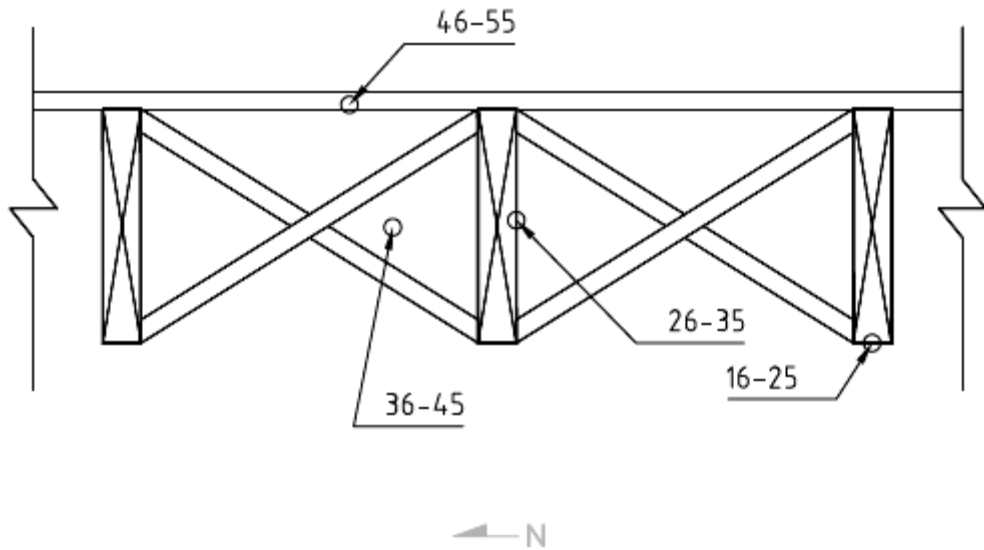

## Elevation - Thermocouple Location

Joist, Plenum, Bottom of Sub Floor

### TC # LOCATION

16-25 On Bottom of Joist

26-35 On Side of Joist at Mid Depth, Facing North

36-45 Mid Depth Between joist

46-55 On Bottom of Subfloor

**Figure A.7.3 – Thermocouple Locations - Elevation.**

Assembly No. 7

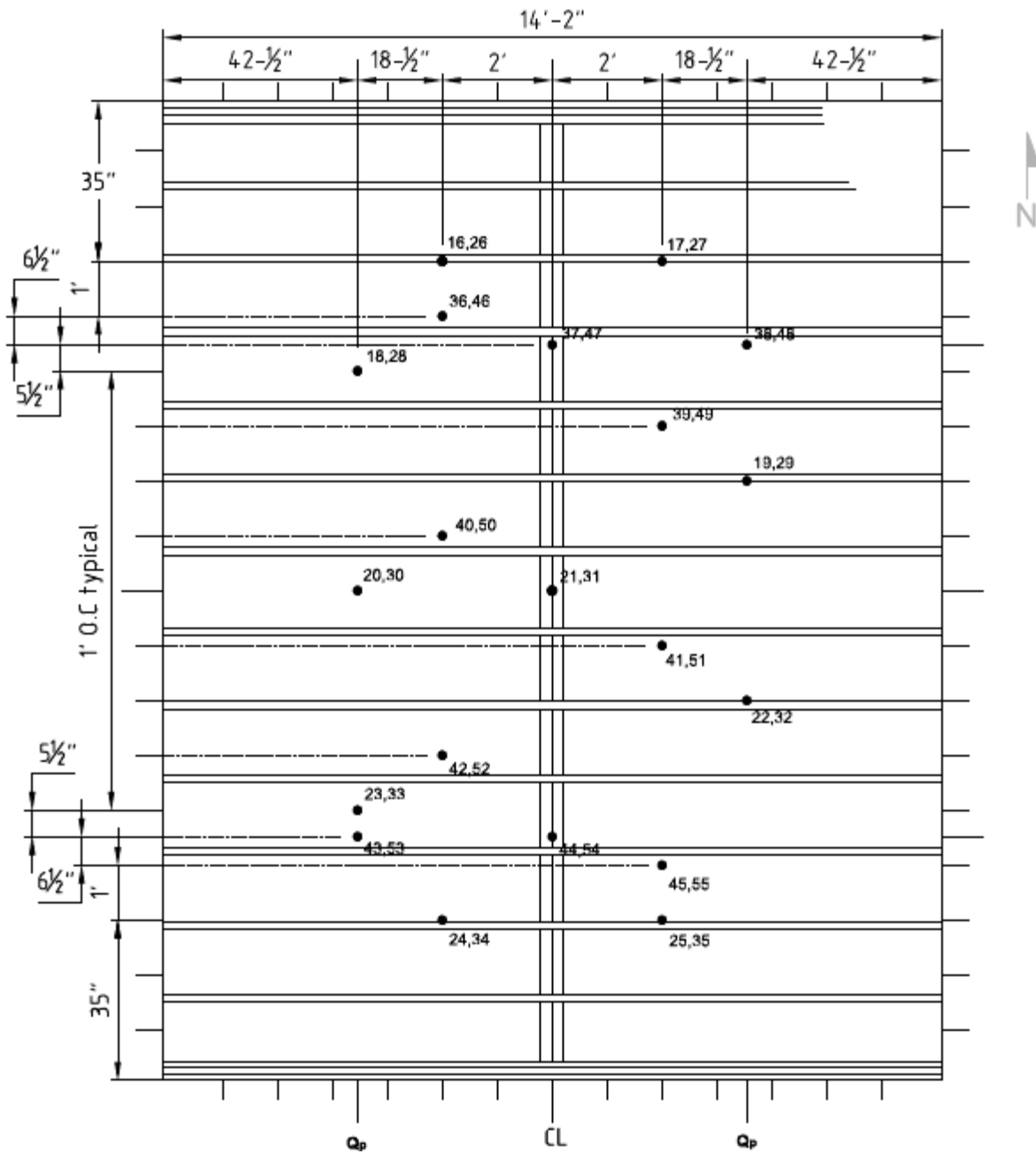

Figure A.7.4 – Thermocouple Locations on Exposed Surface.

Assembly No. 7

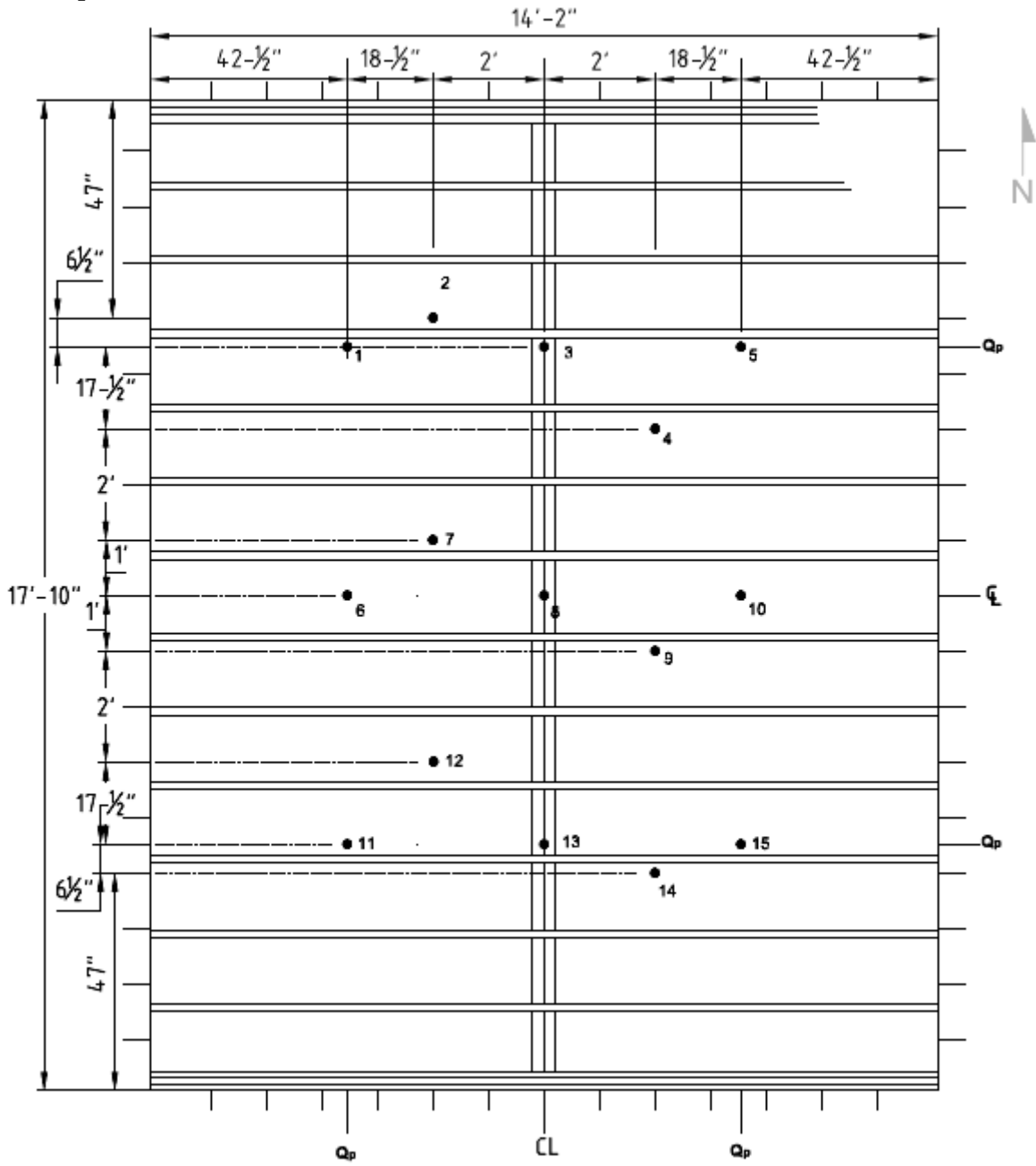

Figure A.7.5 – Thermocouple Locations on Unexposed Surface

Assembly No. 7

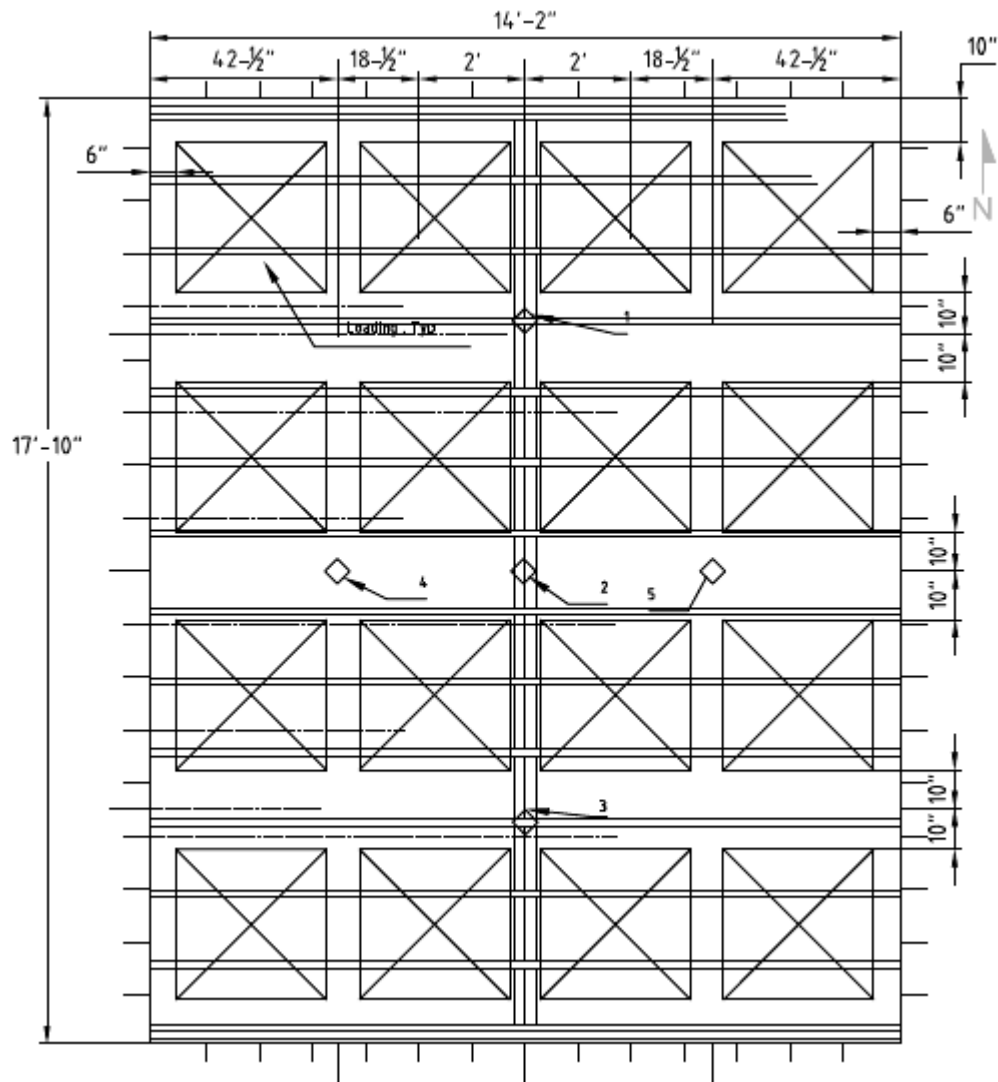



Figure A.7.6 – Loading and Instrumentation Layout (See Figure A.7.7).



Assembly No. 7

**Deflection Transducers:** 

- 1 - Along E-W Centerline, North Quarter-point.
- 2 - Along E-W Centerline, Center-point.
- 3 - Along E-W Centerline, South Quarter-point.
- 4 - Along N-S Centerline, East Quarter-point.
- 5 - Along N-S Centerline, West Quarter-point.

**Audio Recordings: (Not Shown)**

- 1 - At center of assembly hanging 24 in. above subfloor.

**Video Camera Recordings: (Not Shown)**

- Channel 1409 - floor level view from southeast corner
- Channel 1411 - IR camera from curing cell roof east center
- Channel 1412 - furnace camera from northwest corner
- Channel 1416 - overhead from east center of assembly
  
- Channel 1413 - overhead from south center of assembly
- Channel 1503 - overhead from west center of assembly

**Furnace Pressure Probes: (Not Shown)**

- 1 - located near northeast corner
- 2 - located near southwest corner

**Oxygen Content : (Not Shown)**

located in E exhaust duct.

Figure A.7.7 – Loading and Instrumentation Key